



Financial Transmission Rights Auction Example

January 23, 2002

John Lally, ISO New England

At the completion of this presentation, you should be able to ...

- **Understand the concepts and principles of FTRs**
- **Understand how FTRs are acquired in New England**
- **Understand how FTRs are settled in the Day-Ahead Energy Market**

This presentation is based on the FTR Auction example I wrote for section 6 of [M-06 Financial Transmission Right Draft 01-10-02.doc](#) located on

http://www.iso-ne.com/cmsmss/Standard_Market_Design/Draft_Manuals/



Agenda

- **Understanding FTRs**
- **The Five-Bus Power System Model**
- **System Participant Profiles**
- **Annual FTR Auction Example**
- **Monthly FTR Auction Example**
- **Constrained Day-Ahead Energy Market Dispatch Example**
- **Settlement of FTRs in the Day-Ahead Energy Market**



Understanding FTRs

What are FTRs?

An FTR provides a financial hedge in the Day-Ahead Energy Market for the difference in LMP¹ between the source (point of injection in the transmission system) and sink (point of withdrawal).

¹ Although, the LMP is composed of an Energy Component, a Congestion Component, and a Marginal Loss Component, FTRs do not hedge against the Marginal Loss Component.

How are FTRs obtained?

FTRs are obtained by auction ...

- Each FTR bid simulates the delivery of energy between a source and sink
- If more FTRs were granted than could be physically accommodated by the transmission system, the congestion revenue collected in the Day-Ahead Energy Market for energy would be insufficient to hedge the difference in LMPs for the awarded FTRs
- Revenue adequacy is assured in the Day-Ahead Energy Market by ensuring that injections and withdrawals that result from FTRs awarded in the auctions will not overload the NEPOOL Transmission System under normal conditions if a corresponding dispatch were to materialize in the Day-Ahead Energy Market



The Five Bus Power System Model

The PJM Five Bus Power System Model

ISO-NE Normal and Emergency Transmission Line Flow Limits - MW						
Line	E-D	E-A	D-C	C-B	B-A	A-D
Normal Limits	240	400	240	350	250	150
Emergency Limits	440	600	440	550	450	350

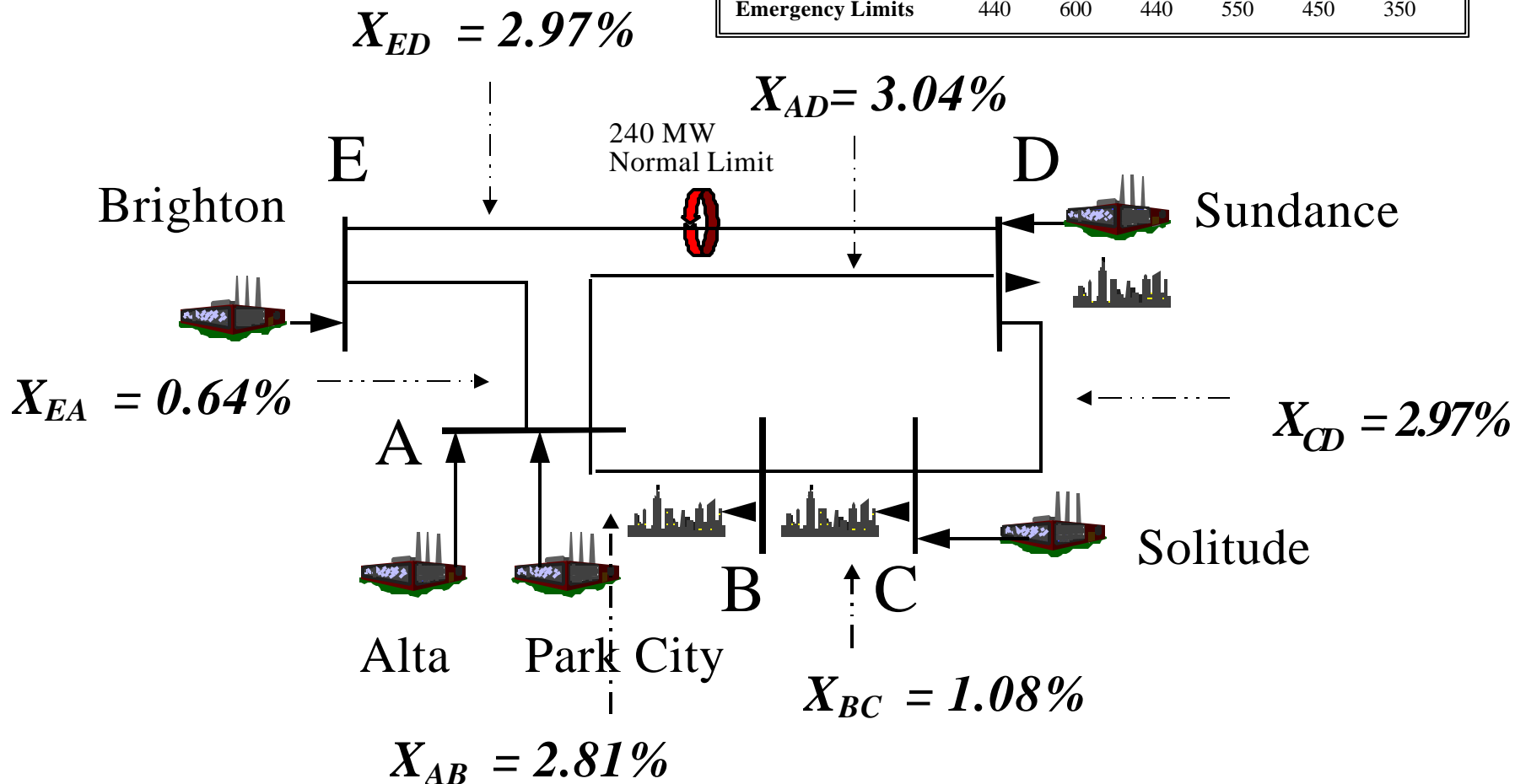

A Simultaneous Feasibility Test (SFT) is an integral part of the process...

- It provides the Linear Programming (LP) based auction and dispatch algorithms with a determination as to whether transmission line flows are physically achievable without exceeding the MW flow limits
- In addition, the SFT used with the auction and dispatch algorithms is used not only to determine secure transmission line flows with all lines in-service, but also to determine secure transmission line flows for each contingency
- The SFT for this example, takes each of the six transmission lines of the five-bus power system model out-of-service one at a time as a separate contingency



System Participant Profiles

System Generation and Peak Load

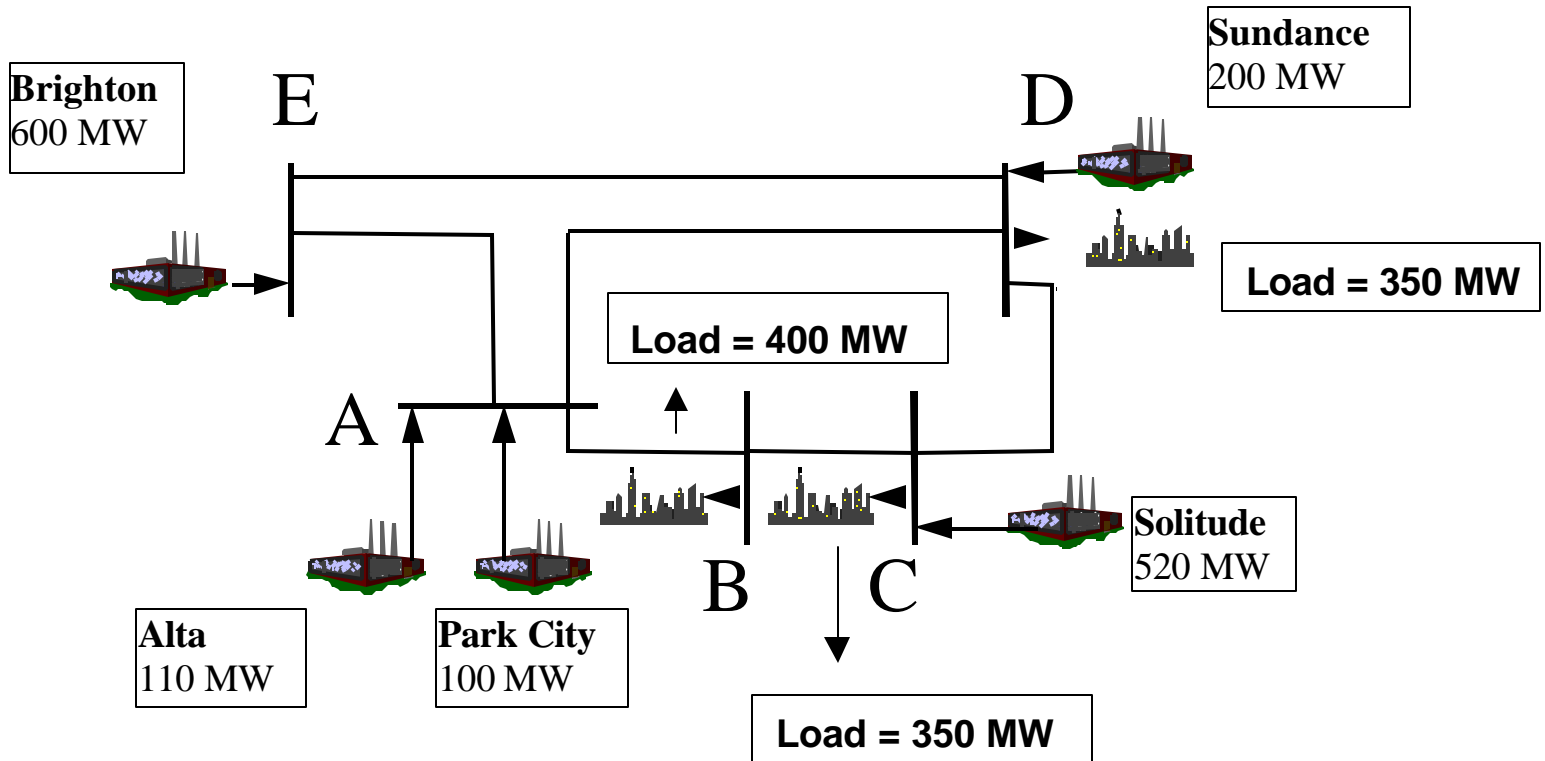



System Participant Profiles

Participant	Generation	Load
Brighton	600 MW Comprised of: <ul style="list-style-type: none"> • 400 MW to LSE B • 200 MW to LSE C 	
Alta	70 MW Comprised of: <ul style="list-style-type: none"> • 70 MW to Bus D for Bilateral Contract 	
LSE B		400 MW Served from: <ul style="list-style-type: none"> • 400 MW from Brighton
LSE C		350 MW Served from: <ul style="list-style-type: none"> • 200 MW from Brighton • *150 MW from Solitude
Solitude	370 MW Comprised of: <ul style="list-style-type: none"> • 220 MW to LSE D • *150 MW to LSE C 	
LSE D		420 MW Served from: <ul style="list-style-type: none"> • 220 MW from Solitude • *130 MW from Sundance • 70 MW from Alta (Bilateral)
Sundance	130 MW Comprised of: <ul style="list-style-type: none"> • *130 MW to LSE D 	

* Generator and Load at same bus

FTRs sought between Generation & Load

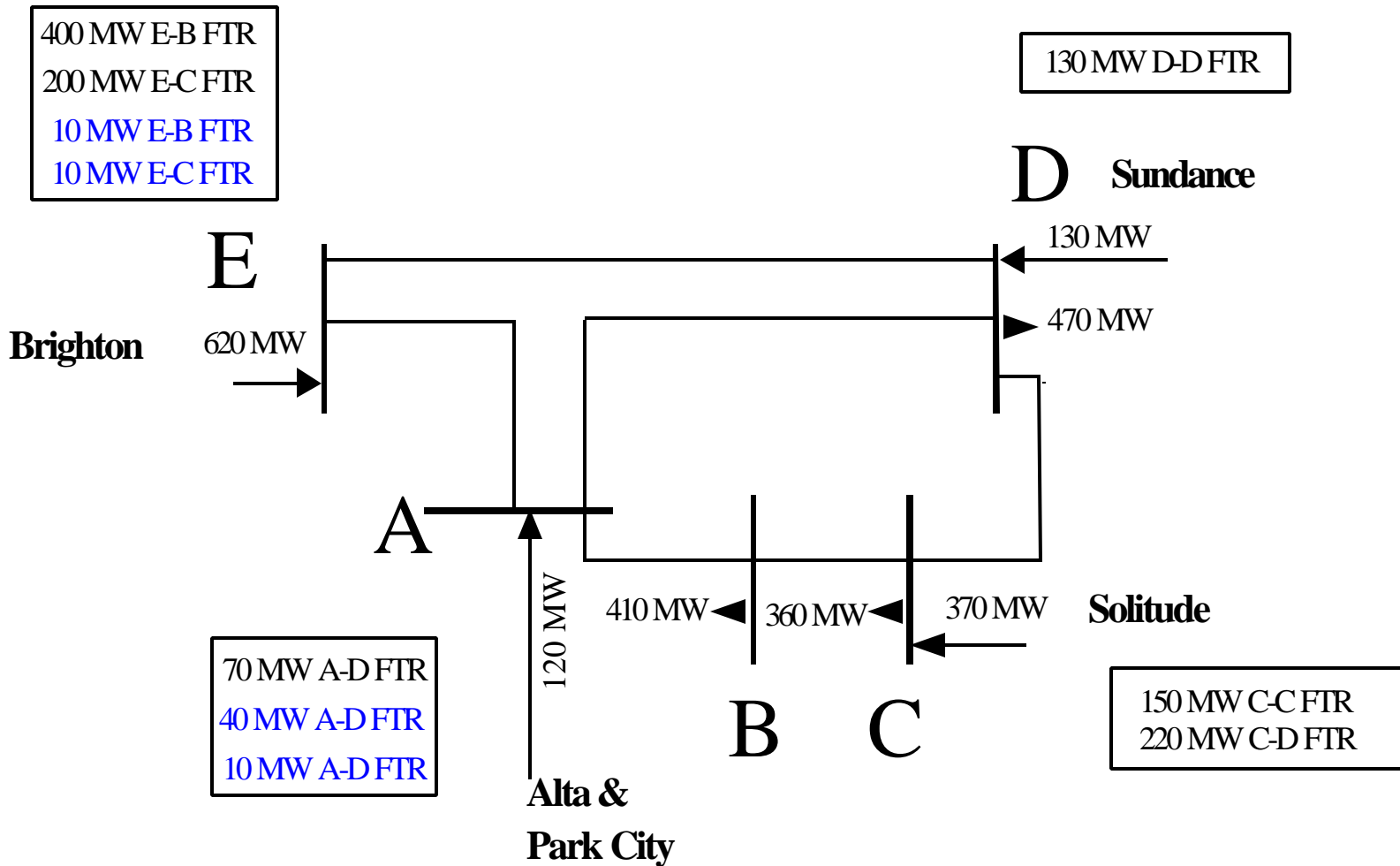



Annual FTR Auction Example

Annual FTR Auction Bids

\$600/MW Buy Bid for 400 MW E-B FTR
 \$700/MW Buy Bid for 200 MW E-C FTR
 \$40/MW Buy Bid for 10 MW E-B FTR
 \$40/MW Buy Bid for 10 MW E-C FTR

\$125/MW Buy Bid for 130 MW D-D FTR

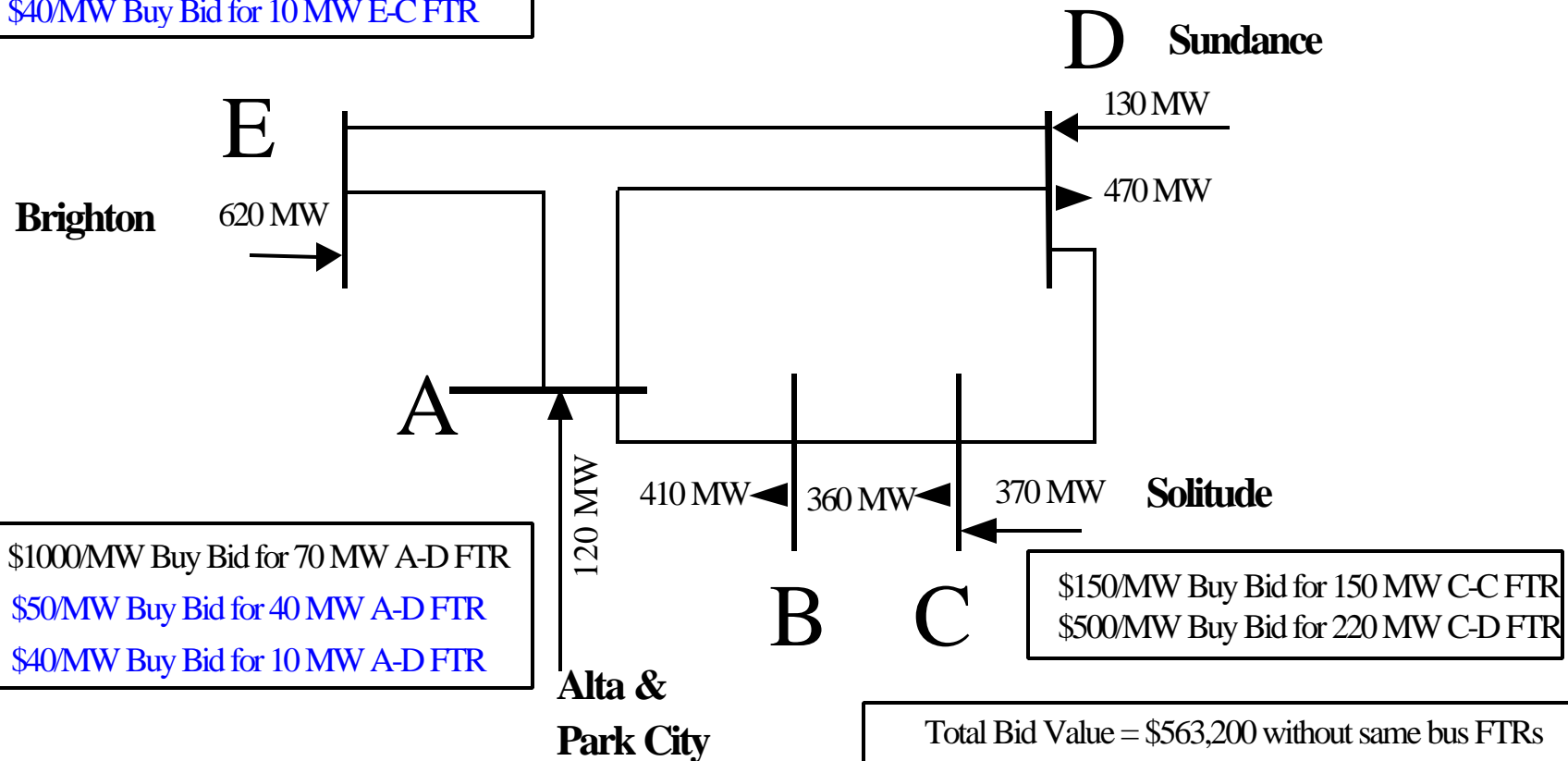

Annual FTR Auction Ignoring Transmission Limits

\$600/MW Buy Bid for 400 MW E-B FTR
 \$700/MW Buy Bid for 200 MW E-C FTR
 \$40/MW Buy Bid for 10 MW E-B FTR
 \$40/MW Buy Bid for 10 MW E-C FTR

\$125/MW Buy Bid for 130 MW D-D FTR

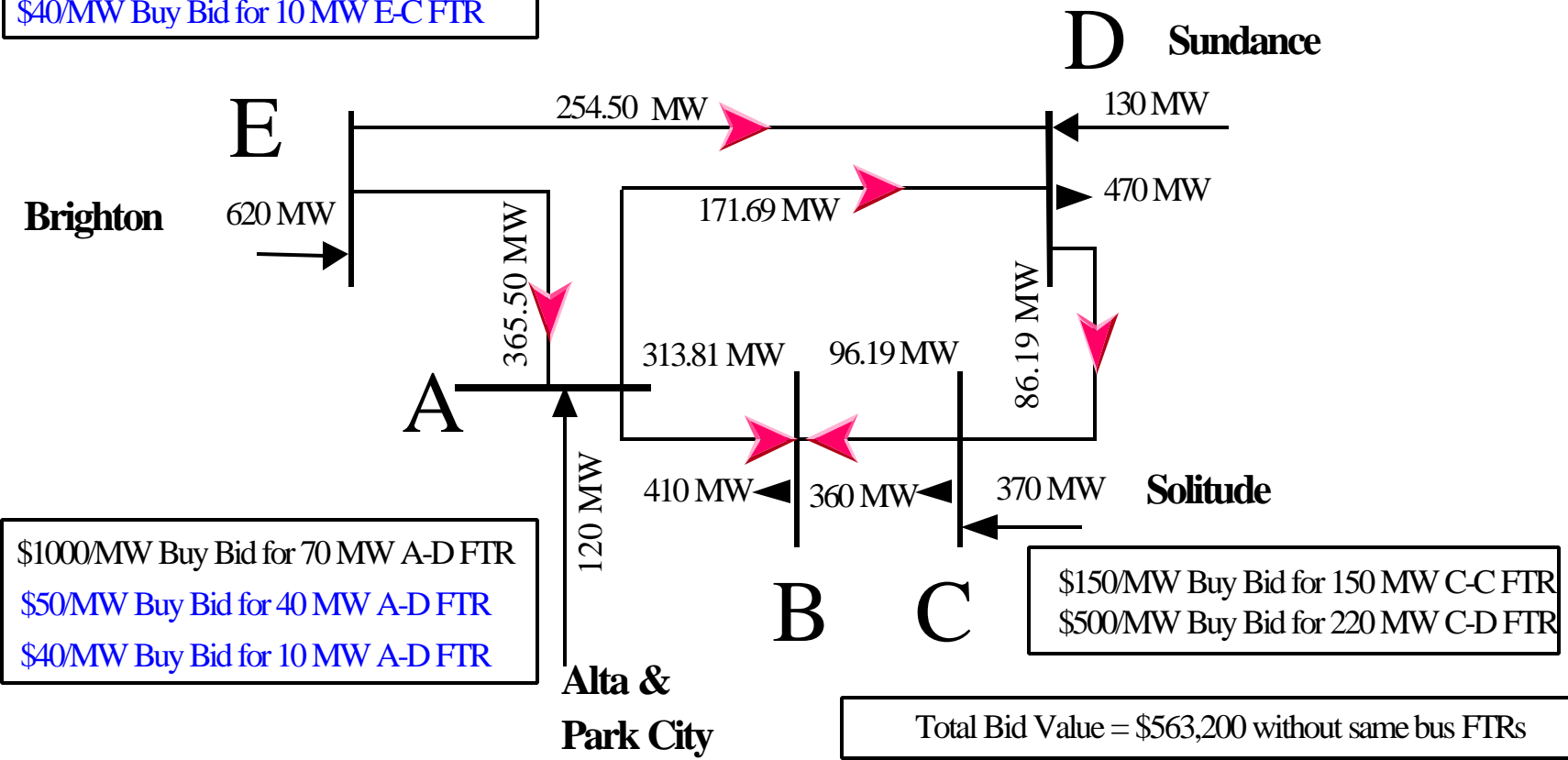

Comparison of Line Flows with Limits - MW

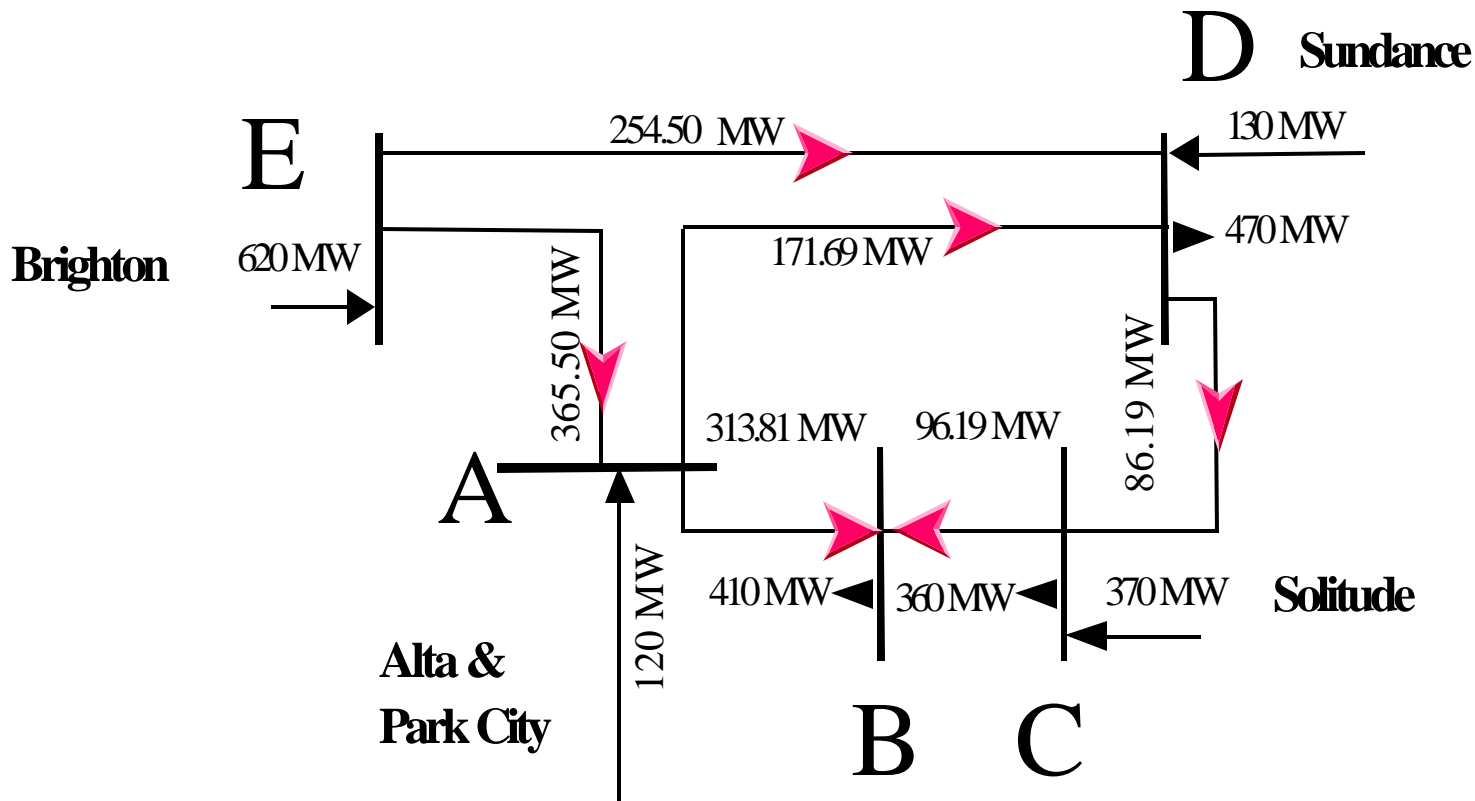

Transmission Line	Pre-Contingency Line Flows with All Lines In-Service	50% of Normal Limits
E-D	254.50	120
E-A	365.50	200
D-C	86.19	120
C-B	96.19	175
B-A	-313.81	125
A-D	171.69	75

Contingency Line Flows Compared with Limits - MW

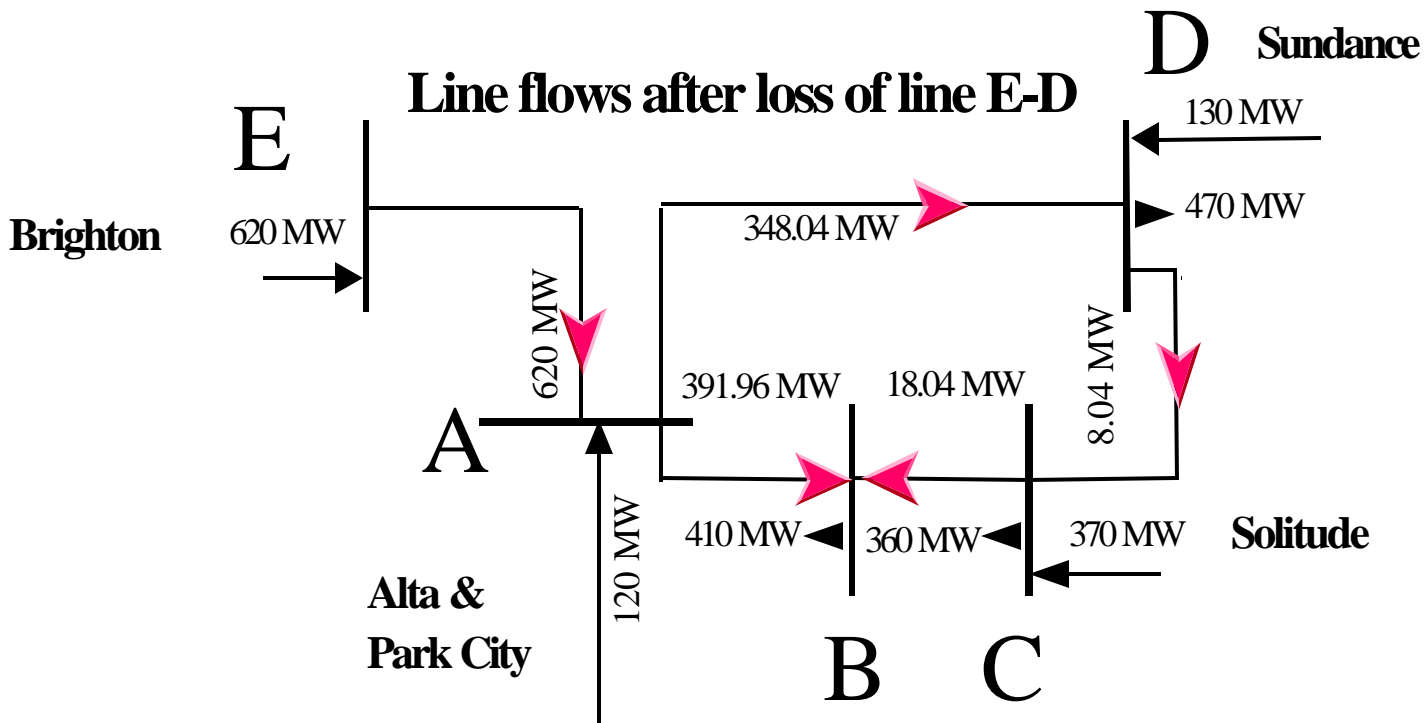

Transmission Line	Pre-Contingency Line Flows with All Lines In-Service	50% of Normal Limits	Post-Contingency Line Flows after Loss of Indicated Line						50% of Emergency Limits
			E-D	E-A	D-C	C-B	B-A	A-D	
E-D	254.50	120	0.00	620.00	215.10	210.53	397.95	366.99	220
E-A	365.50	200	620.00	0.00	404.90	409.47	222.05	253.01	300
D-C	86.19	120	8.04	198.42	0.00	-10.00	400.00	26.99	220
C-B	96.19	175	18.04	208.42	10.00	0.00	410.00	36.99	275
B-A	-313.81	125	-391.96	-201.58	-400.00	-410.00	0.00	-373.01	225
A-D	171.69	75	348.04	-81.58	124.90	119.47	342.05	0.00	175

Annual FTR Auction Respecting Transmission Limits

220 of 400 MW E-B FTR Selected @\$600/MW
 0 of 200 MW E-C FTR Selected @\$700/MW
 0 of 10 MW E-B FTR Selected @\$40/MW
 0 of 10 MW E-C FTR Selected @\$40/MW

130 of 130 MW D-D FTR Selected @\$125/MW

All lines at 50% of normal and emergency limits

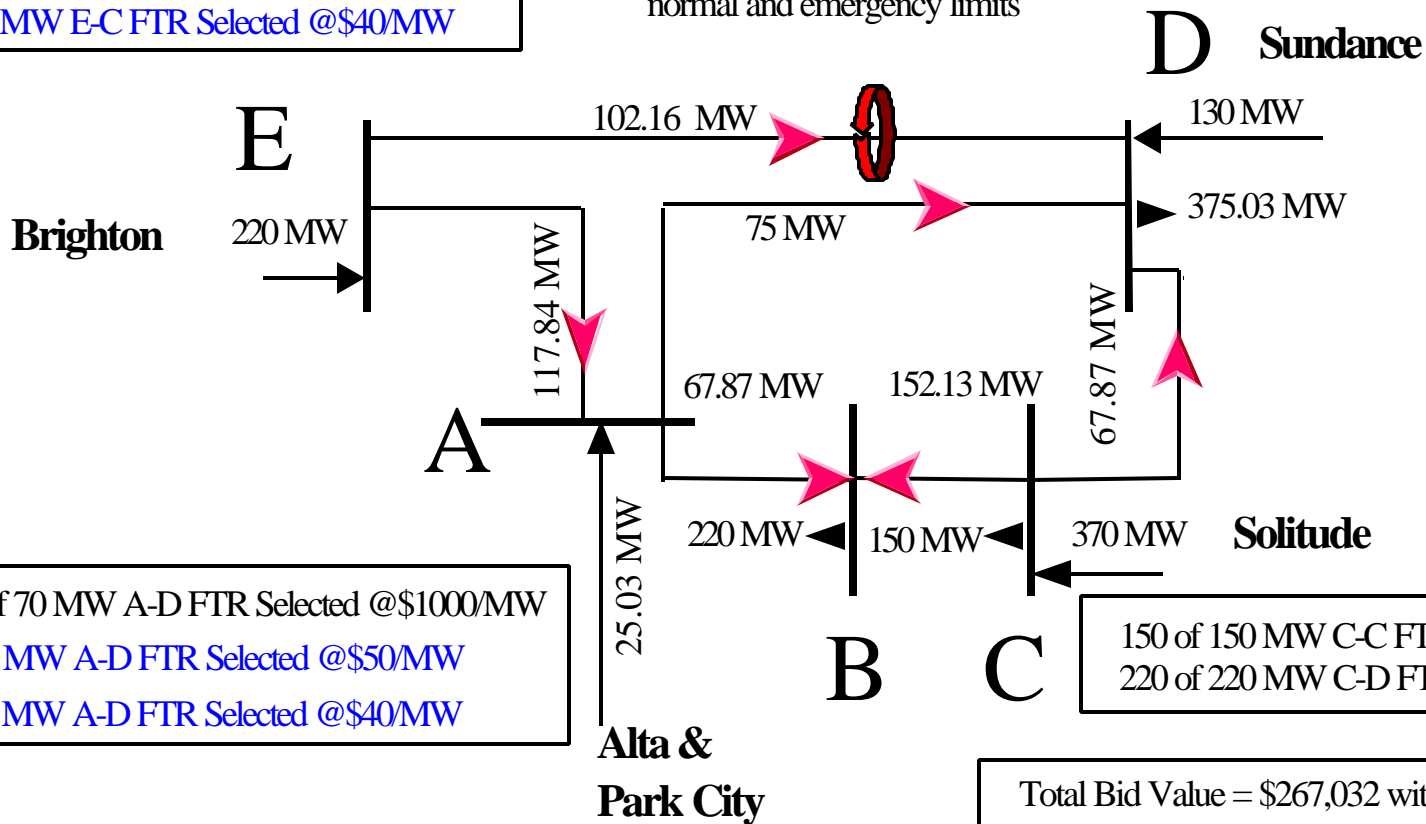

25.03 of 70 MW A-D FTR Selected @\$1000/MW
 0 of 40 MW A-D FTR Selected @\$50/MW
 0 of 10 MW A-D FTR Selected @\$40/MW

150 of 150 MW C-C FTR Selected @\$150/MW
 220 of 220 MW C-D FTR Selected @\$500/MW

Total Bid Value = \$267,032 without same bus FTRs

Contingency Line Flows Compared with Limits - MW

Line flows after loss of line E-A

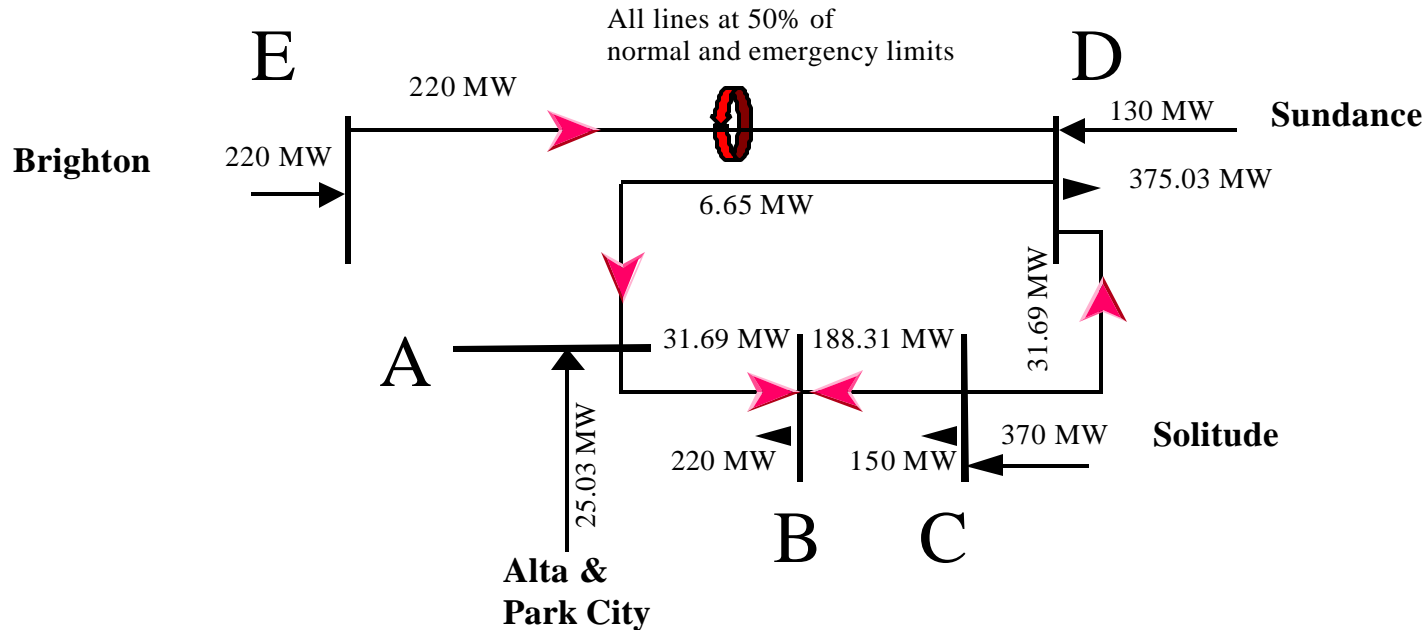

Transmission Line	Pre-Contingency Line Flows with All Lines In-Service	50% of Normal Limits	Post-Contingency Line Flows after Loss of Indicated Line						50% of Emergency Limits
			E-D	E-A	D-C	C-B	B-A	A-D	
E-D	102.16	120	0.00	220.00	133.19	32.62	133.19	151.30	220
E-A	117.84	200	220.00	0.00	86.81	187.38	86.81	68.70	300
D-C	-67.87	120	-99.24	-31.69	0.00	-220.00	0.00	-93.73	220
C-B	152.13	175	120.76	188.31	220.00	0.00	220.00	126.27	275
B-A	-67.87	125	-99.24	-31.69	0.00	-220.00	0.00	-93.73	225
A-D	75.00	75	145.79	-6.65	111.84	-7.58	111.84	0.00	175



Annual FTR Auction Selection of Winning Bids

1	2	3	4		5 = 3 / 4		6	7 = 3 * 6	8 = 4 * 6	
Bid Path	Bid Quantity (MW)	Bid Price (\$/MW)	Sensitivity Factors ¹		Cost Effectiveness Ratio (\$/MW)		FTRs Selected (MW)	Auction Value \$	Flow on Constrained Lines (MW)	
			Line A-D	Line E-D	Line A-D	Line E-D			Line A-D	Line E-D
E-B	400	600	0.1017	1.0000	5902	600	220	\$132,000	22.37	220.00
E-C	200	700	0.1706	1.0000	4104	700	0	\$0	0.00	0.00
C-D	220	500	0.1895	0.0000	2639	0	220	\$110,000	41.68	0.00
A-D	70	1000	0.4376	0.0000	2285	0	25.03239	\$25,032	10.95	0.00
A-D	40	50	0.4376	0.0000	114	0	0	\$0	0.00	0.00
E-B	10	40	0.1017	1.0000	393	40	0	\$0	0.00	0.00
A-D	10	40	0.4376	0.0000	91	0	0	\$0	0.00	0.00
E-C	10	40	0.1706	1.0000	235	40	0	\$0	0.00	0.00
								\$267,032	75.00	220.00

¹ Sensitivity factors change under contingencies. Sensitivity factors for line A-D are for all lines in-service. Sensitivity factors for line E-D result from the contingent loss of line E-A.



Annual FTR Auction Clearing Prices

From Bus A	Calculation for Components of FTR Clearing Price		FTR Clearing Price = S Cost Components
	Binding Constraint A-D \$2285.254	Binding Constraint E-D \$367.664	
A	Reference	Reference	\$0.00
B	$\$2285.254 * 0.179245$	$\$367.664 * 0.0$	\$409.62
C	$\$2285.254 * 0.248137$	$\$367.664 * 0.0$	\$567.06
D	$\$2285.254 * 0.437588$	$\$367.664 * 0.0$	\$1000.00
E	$\$2285.254 * 0.077578$	$\$367.664 * -1.0$	-\$190.38

Lagrange Multiplier for Binding Constraint A-D

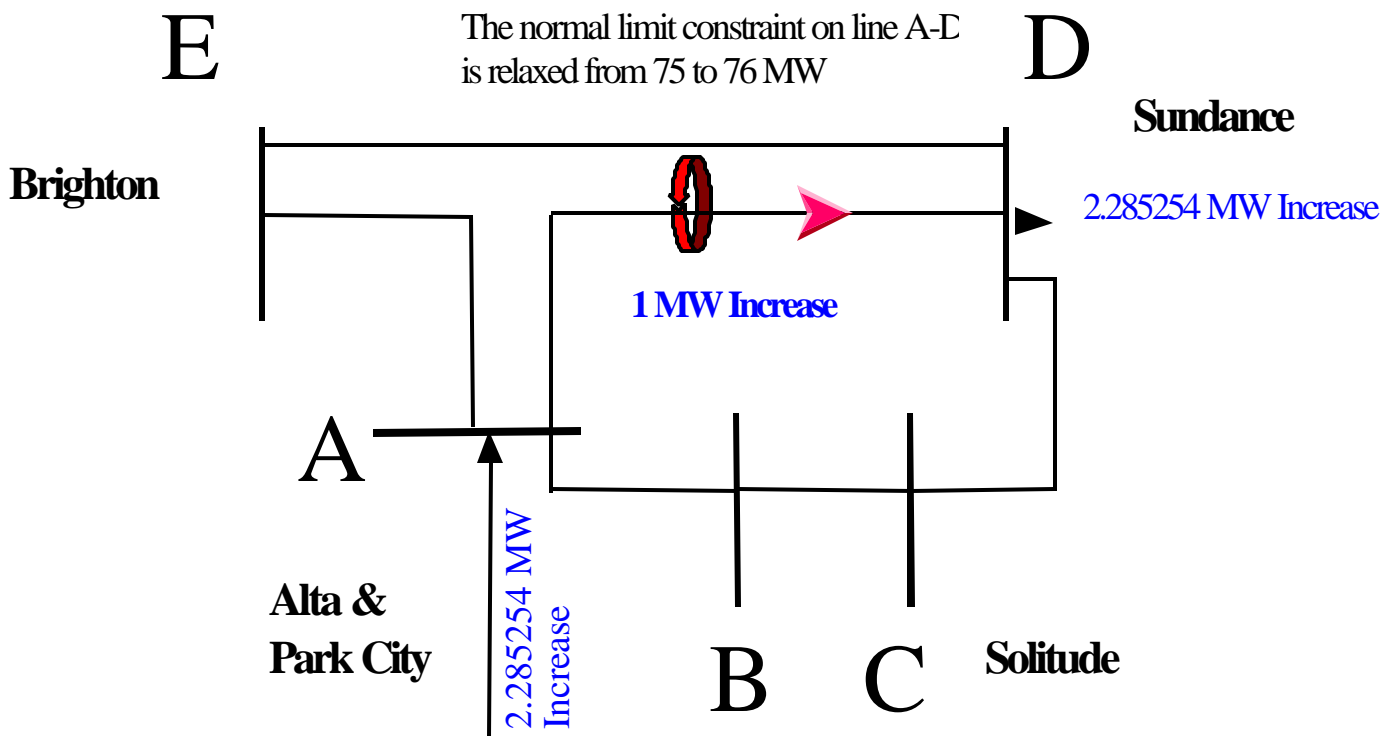

2.285254 MW A-D FTR Increase @\$1000/MW

Total FTR Auction Value Increase = \$2,285.254

Bus D Sensitivity Factor for Constraint on A-D

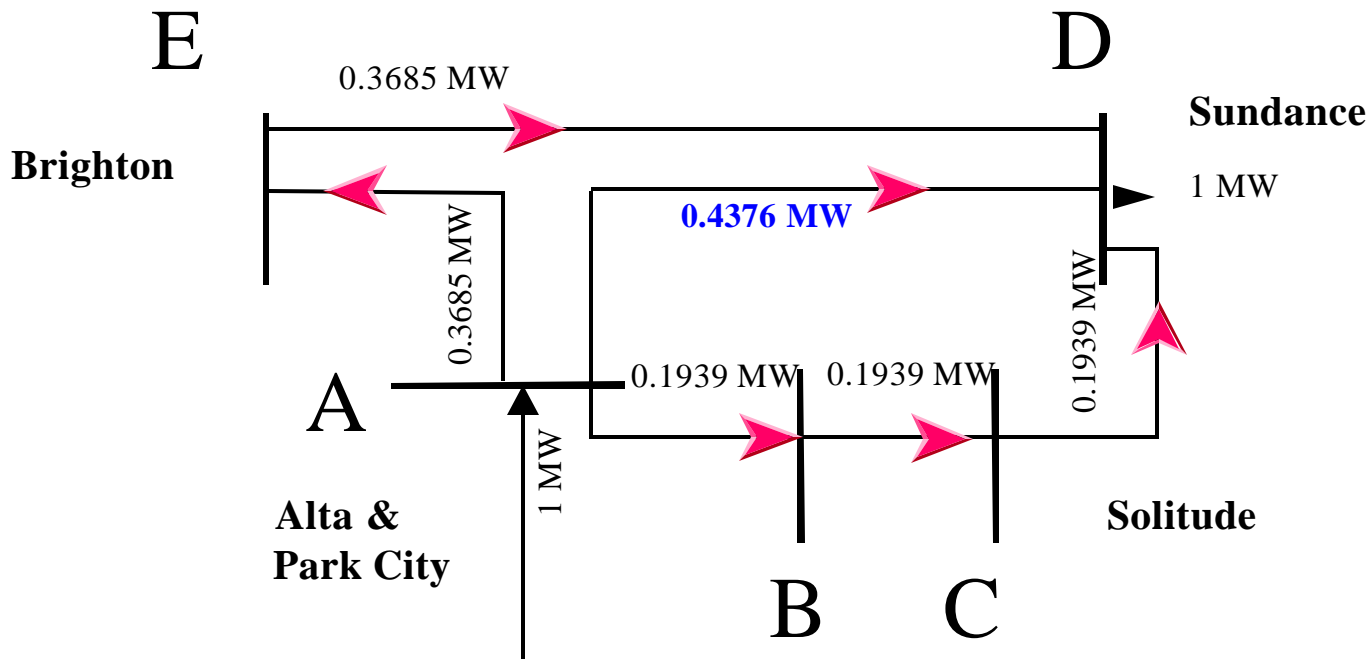

From Bus A	Calculation for Components of FTR Clearing Price	
	Binding Constraint A-D \$2285.254	Binding Constraint E-D \$367.664
A	Reference	Reference
B	$\$2285.254 * 0.179245$	$\$367.664 * 0.0$
C	$\$2285.254 * 0.248137$	$\$367.664 * 0.0$
D	$\$2285.254 * 0.437588$	$\$367.664 * 0.0$
E	$\$2285.254 * 0.077578$	$\$367.664 * -1.0$

Bus E Sensitivity Factor for Constraint on A-D

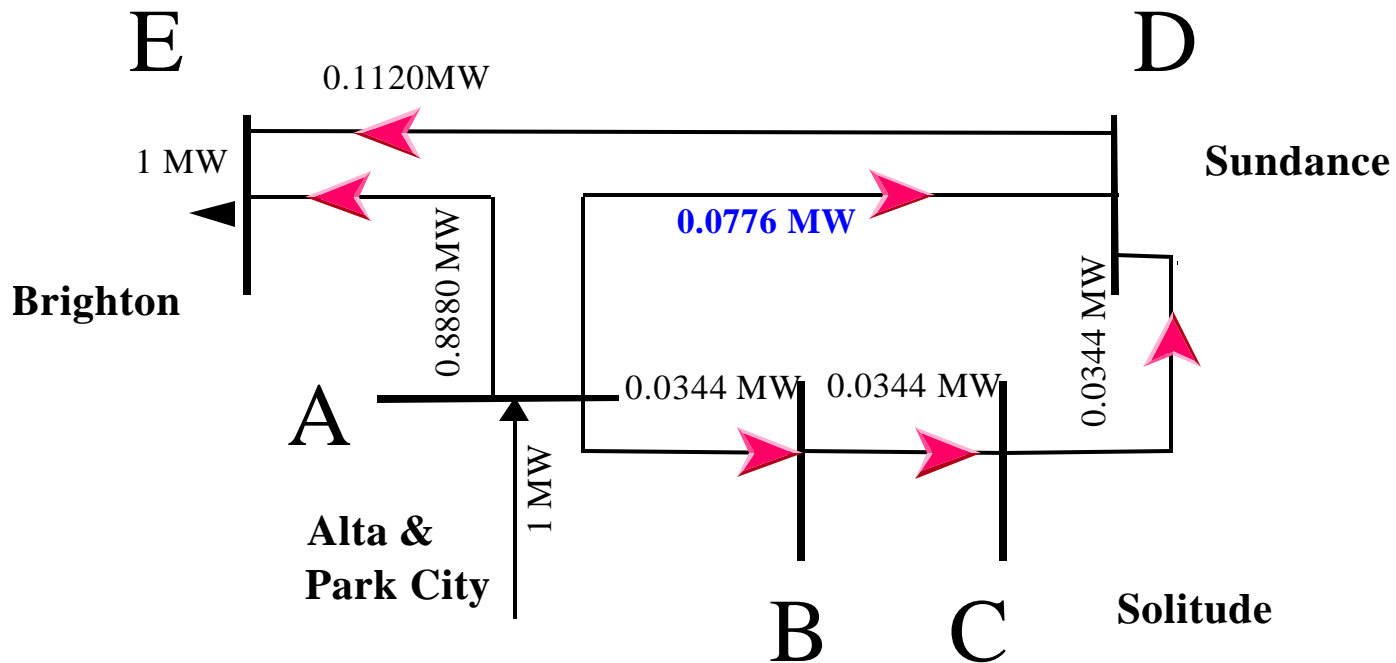

From Bus A	Calculation for Components of FTR Clearing Price	
	Binding Constraint A-D \$2285.254	Binding Constraint E-D \$367.664
A	Reference	Reference
B	$\$2285.254 * 0.179245$	$\$367.664 * 0.0$
C	$\$2285.254 * 0.248137$	$\$367.664 * 0.0$
D	$\$2285.254 * 0.437588$	$\$367.664 * 0.0$
E	$\$2285.254 * 0.077578$	$\$367.664 * -1.0$

Lagrange Multiplier for Binding Constraint E-D

1 MW E-B FTR Increase @\$600/MW

Line flows after loss of line E-A

The emergency limit constraint on line E-D is relaxed from 220 to 221 MW

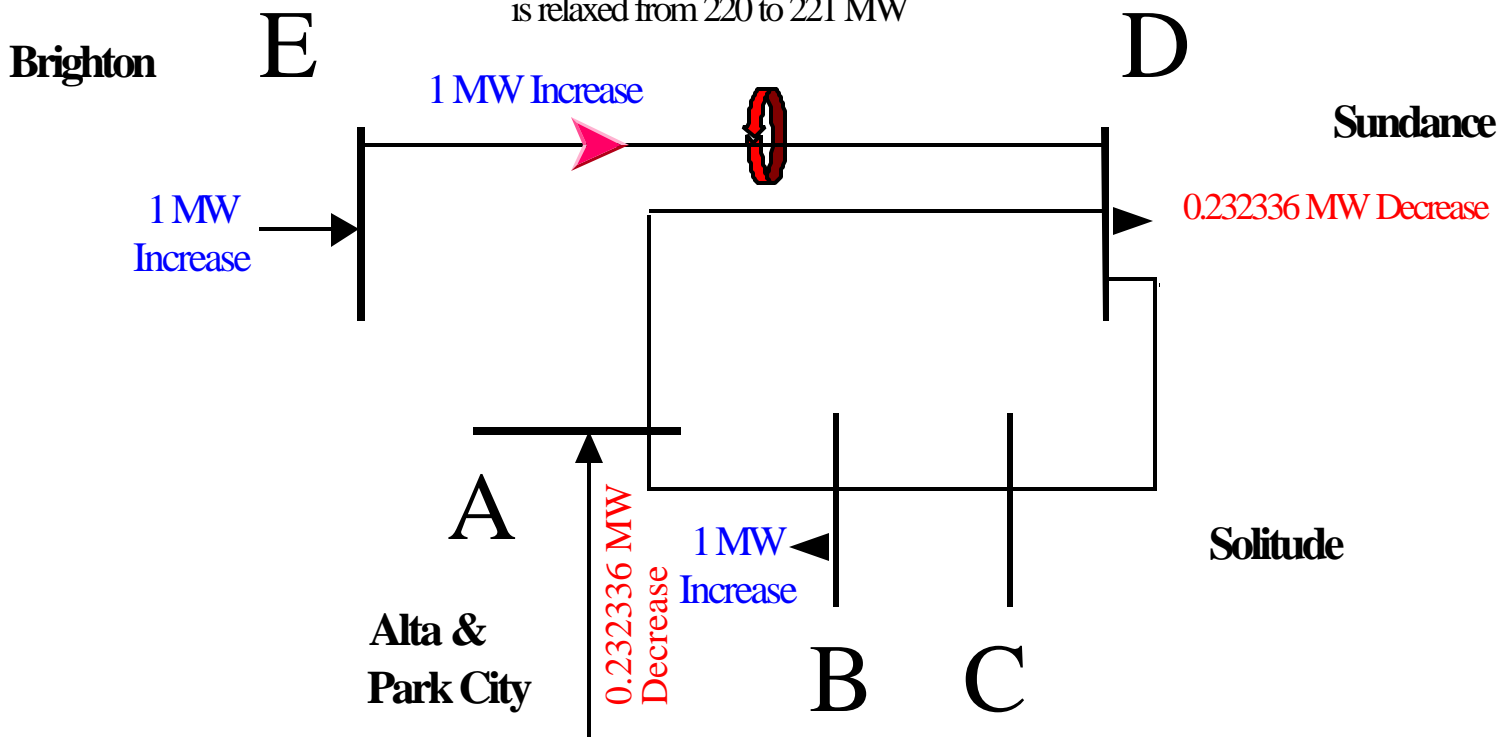

0.232336 MW A-D FTR Decrease @1000/MW
To respect line A-D limit with all lines in

Total FTR Auction Value Increase = \$367.664

Bus E Sensitivity Factor for Constraint on E-D

Line flows after loss of line E-A

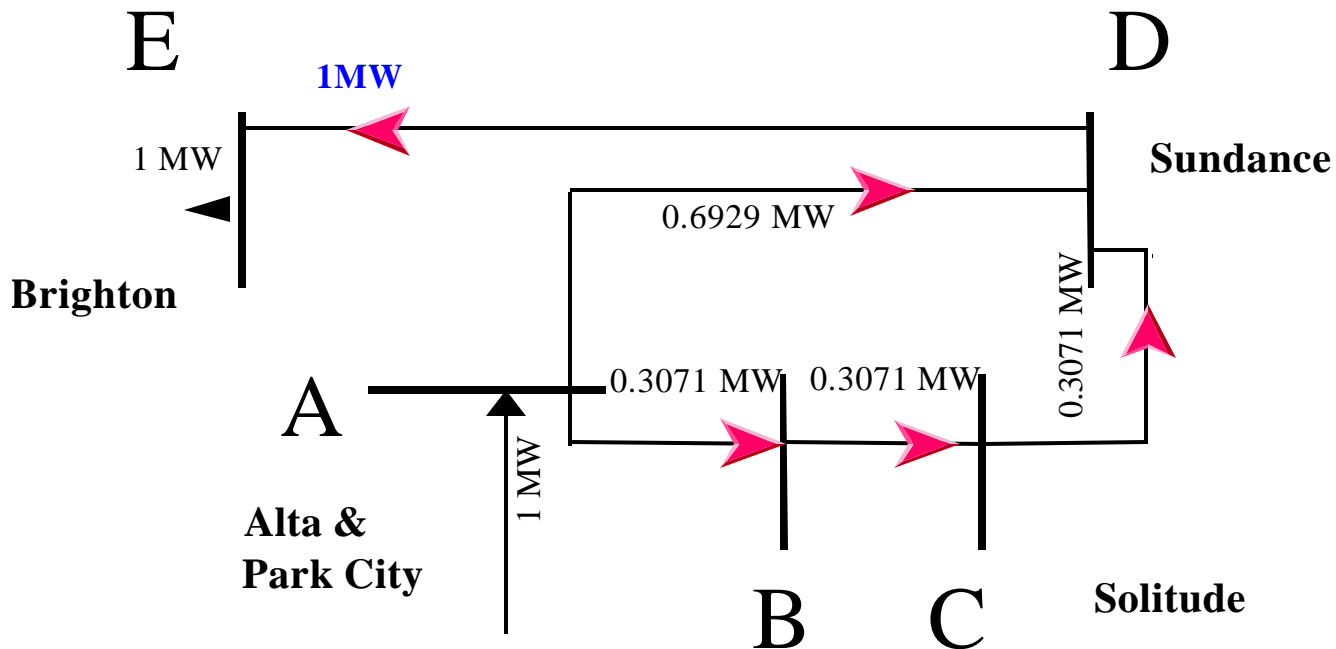

From Bus A	Calculation for Components of FTR Clearing Price	
	Binding Constraint A-D \$2285.254	Binding Constraint E-D \$367.664
A	Reference	Reference
B	$\$2285.254 * 0.179245$	$\$367.664 * 0.0$
C	$\$2285.254 * 0.248137$	$\$367.664 * 0.0$
D	$\$2285.254 * 0.437588$	$\$367.664 * 0.0$
E	$\$2285.254 * 0.077578$	$\$367.664 * -1.0$

Bus D Sensitivity Factor for Constraint on E-D

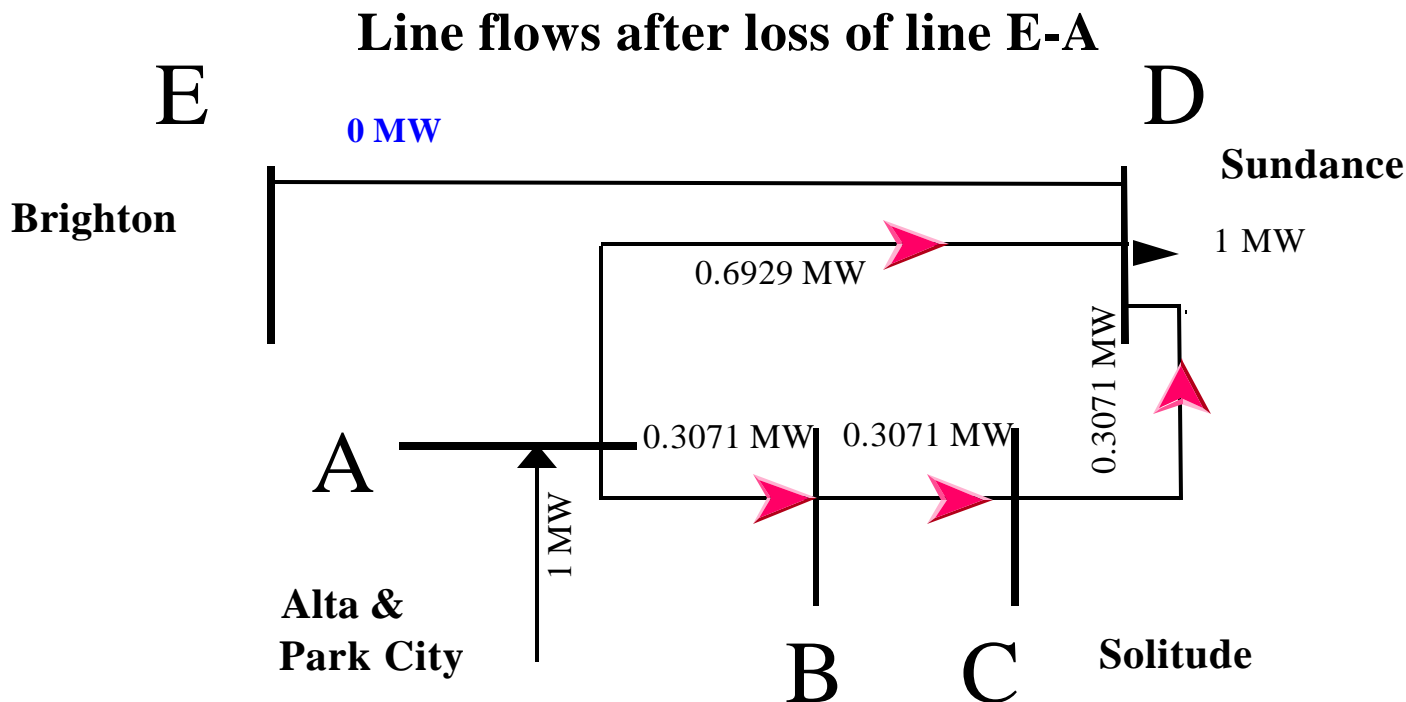

From Bus A	Calculation for Components of FTR Clearing Price	
	Binding Constraint A-D \$2285.254	Binding Constraint E-D \$367.664
A	Reference	Reference
B	$\$2285.254 * 0.179245$	$\$367.664 * 0.0$
C	$\$2285.254 * 0.248137$	$\$367.664 * 0.0$
D	$\$2285.254 * 0.437588$	$\$367.664 * 0.0$
E	$\$2285.254 * 0.077578$	$\$367.664 * -1.0$

Annual FTR Auction Respecting Transmission Limits

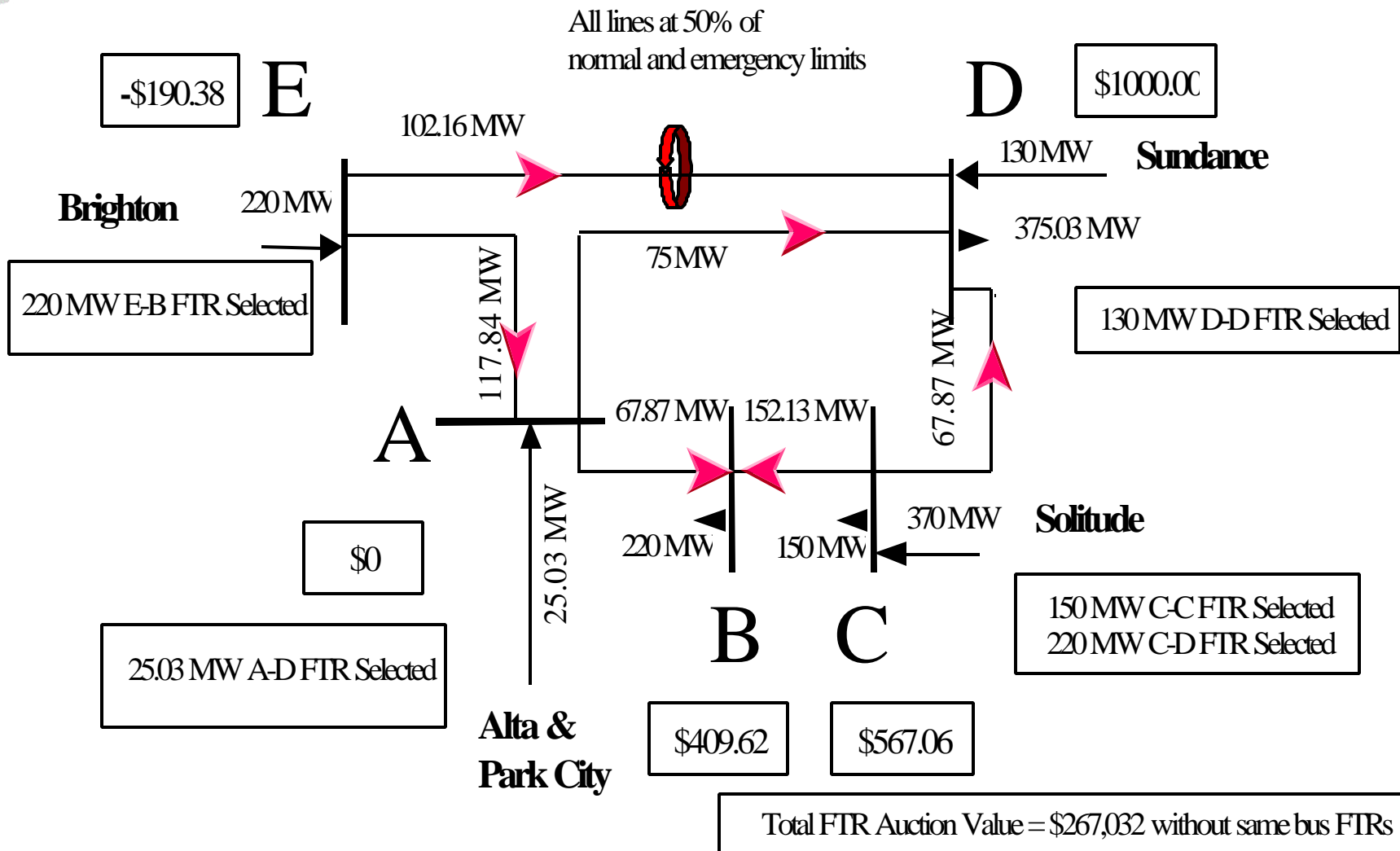



Annual FTR Auction Clearing Prices

From Bus A	Calculation for Components of FTR Clearing Price		FTR Clearing Price = S Cost Components
	Binding Constraint A-D \$2285.254	Binding Constraint E-D \$367.664	
A	Reference	Reference	\$0.00
B	$\$2285.254 * 0.179245$	$\$367.664 * 0.0$	\$409.62
C	$\$2285.254 * 0.248137$	$\$367.664 * 0.0$	\$567.06
D	$\$2285.254 * 0.437588$	$\$367.664 * 0.0$	\$1000.00
E	$\$2285.254 * 0.077578$	$\$367.664 * -1.0$	-\$190.38

Annual FTR Auction Clearing Prices by Path - \$/MW

Source \ Sink	A	B	C	D	E
A	0	409.62	567.06	1000	-190.38
B	-409.62	0	157.44	590.38	-600
C	-567.06	-157.44	0	432.94	-757.44
D	-1000	-590.38	-432.94	0	-1190.38
E	190.38	600	757.44	1190.38	0

Annual FTR Auction Results

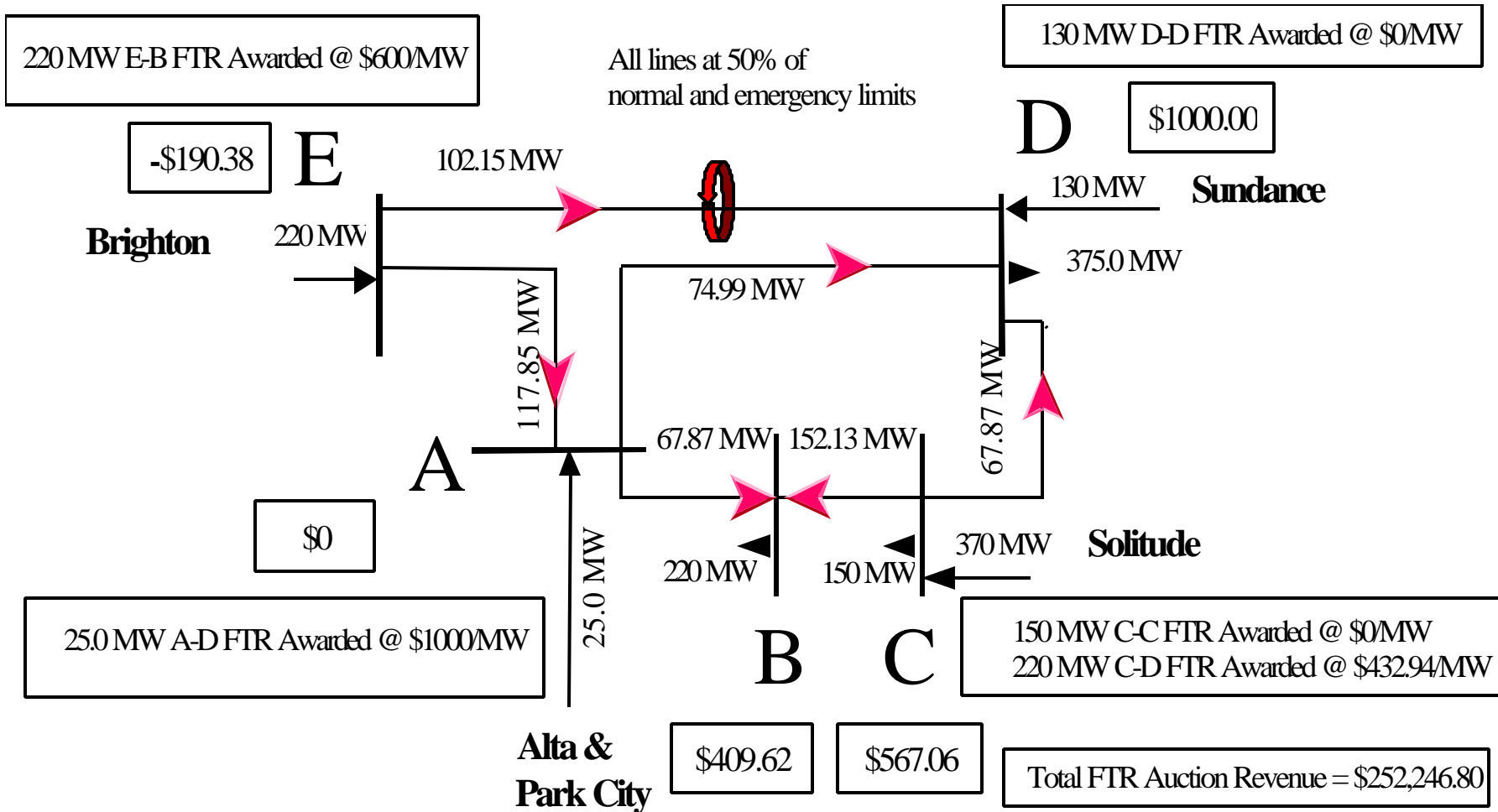



Monthly FTR Auction Example

Monthly FTR Auction Bids

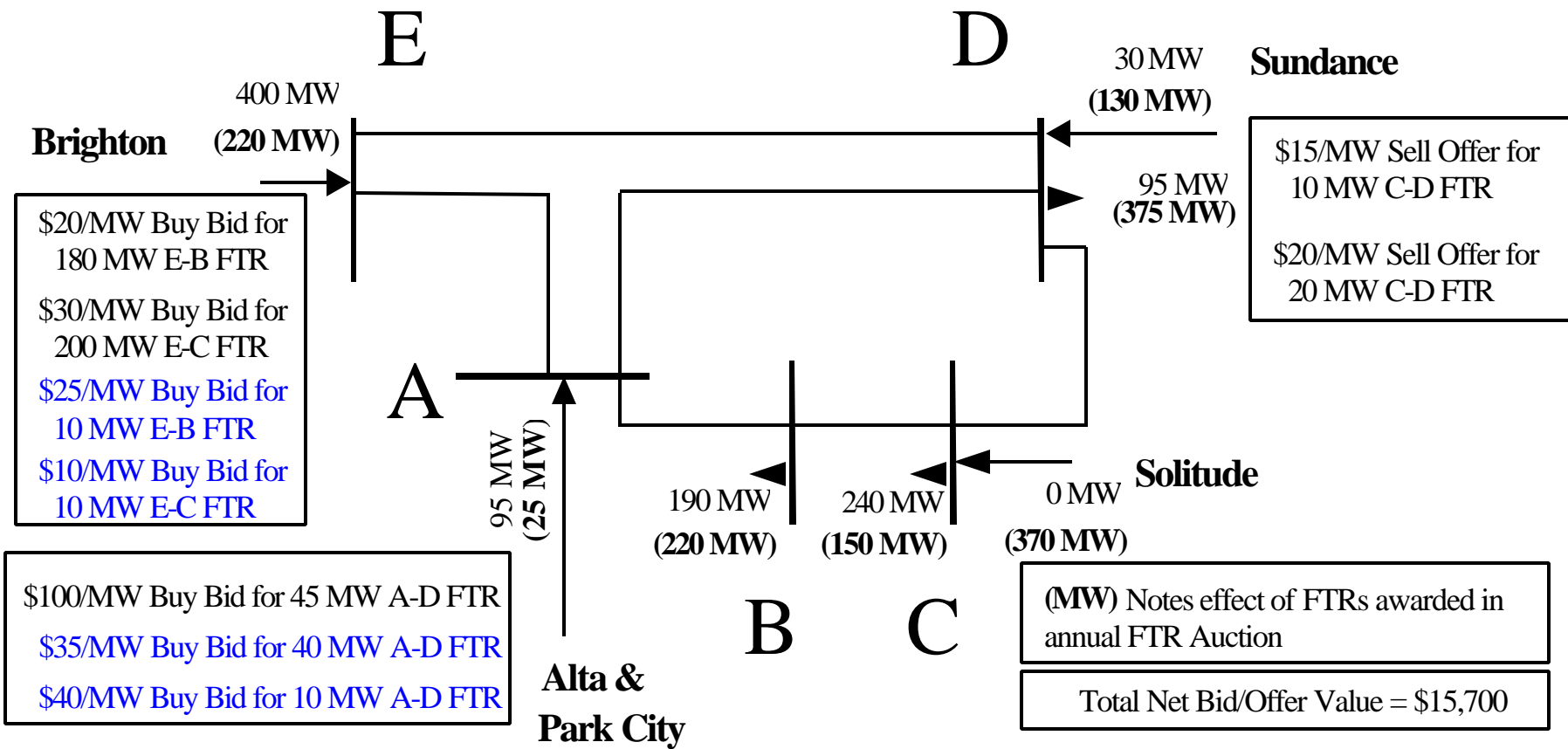

Monthly Auction Ignoring Transmission Limits

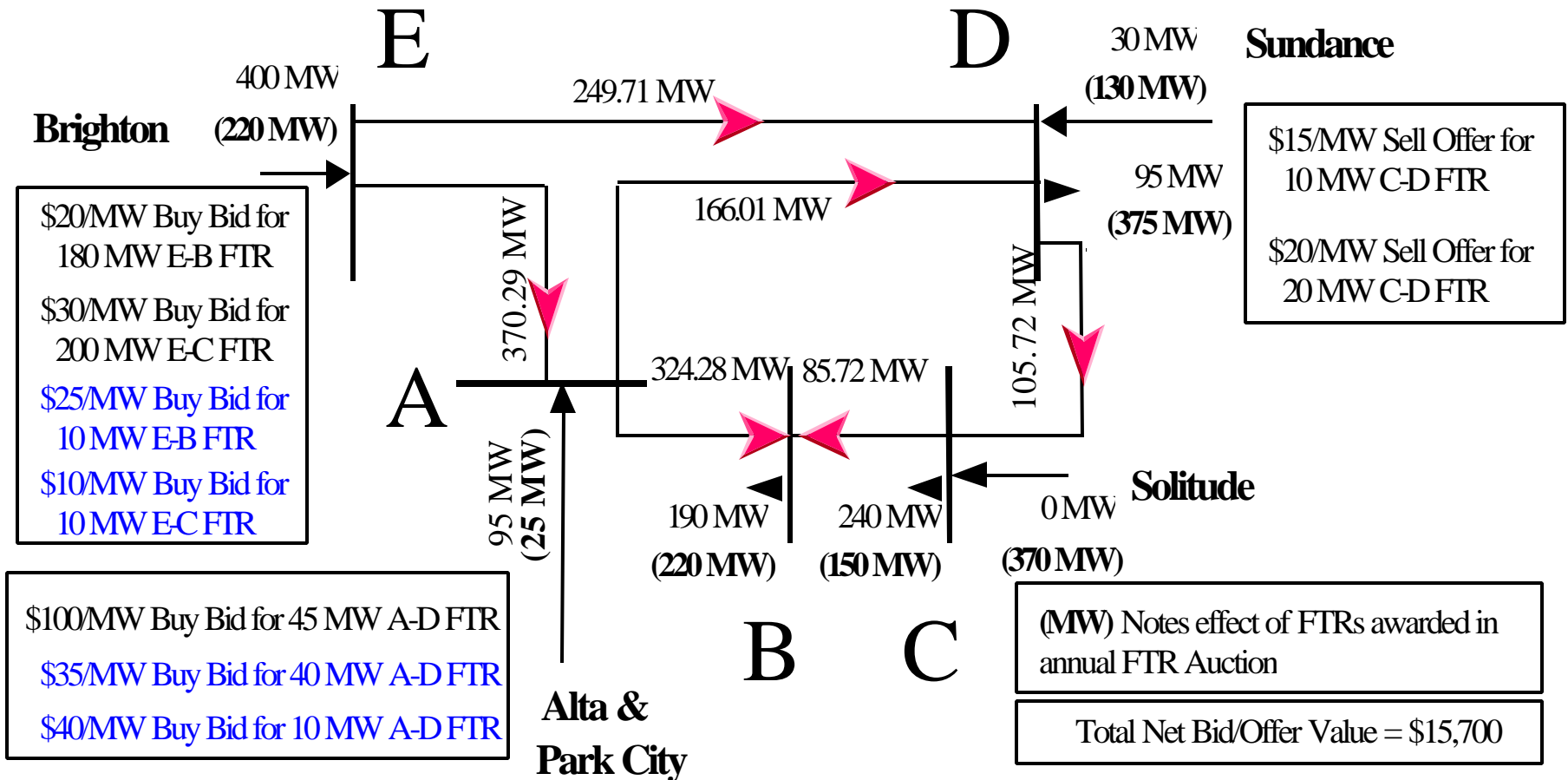

Comparison of Line Flows with Limits - MW

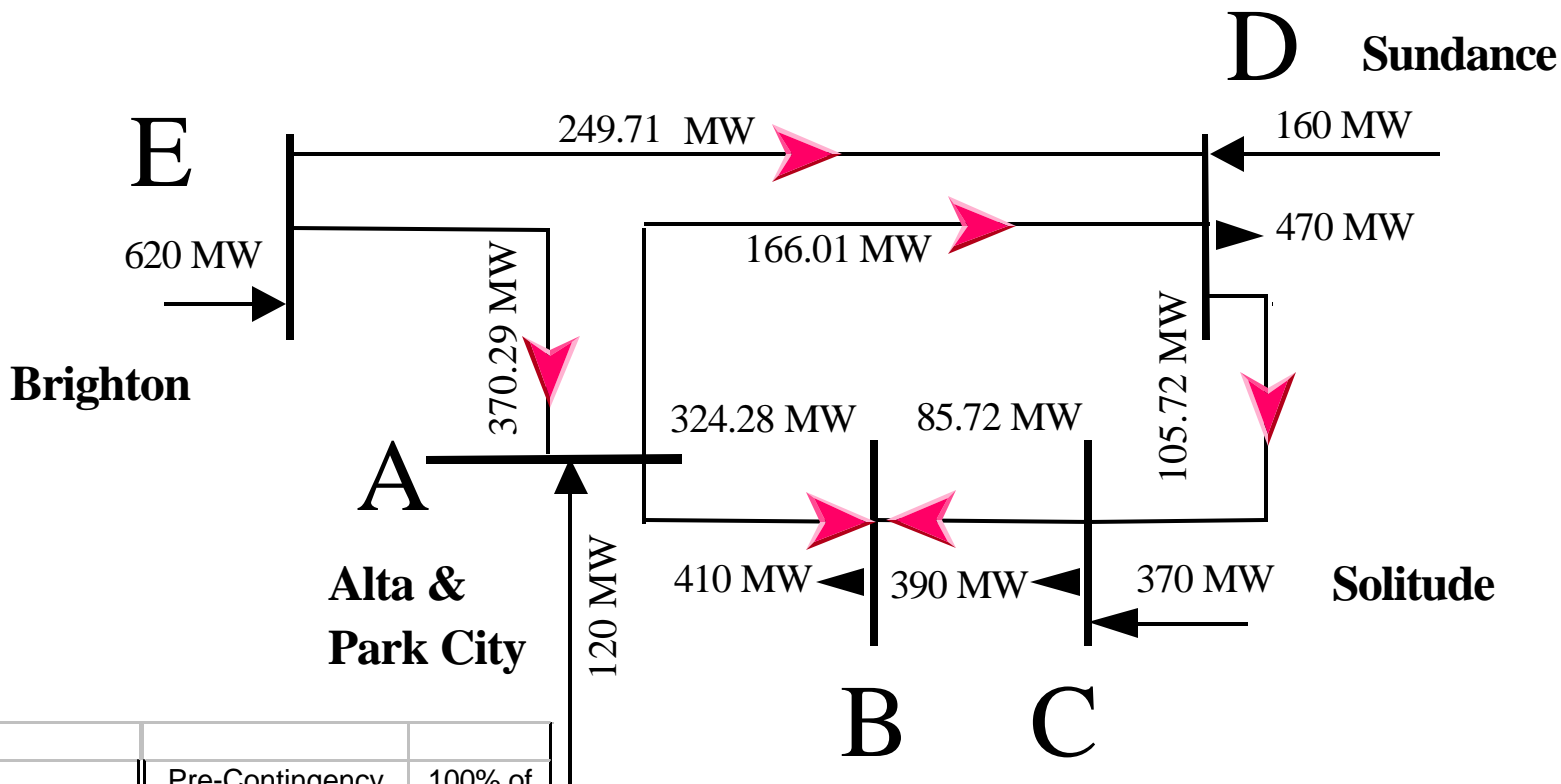

Transmission Line	Pre-Contingency Line Flows with All Lines In-Service	100% of Normal Limits
E-D	249.71	240
E-A	370.29	400
D-C	105.72	240
C-B	85.72	350
B-A	-324.28	250
A-D	166.01	150

Contingency Line Flows Compared with Limits - MW

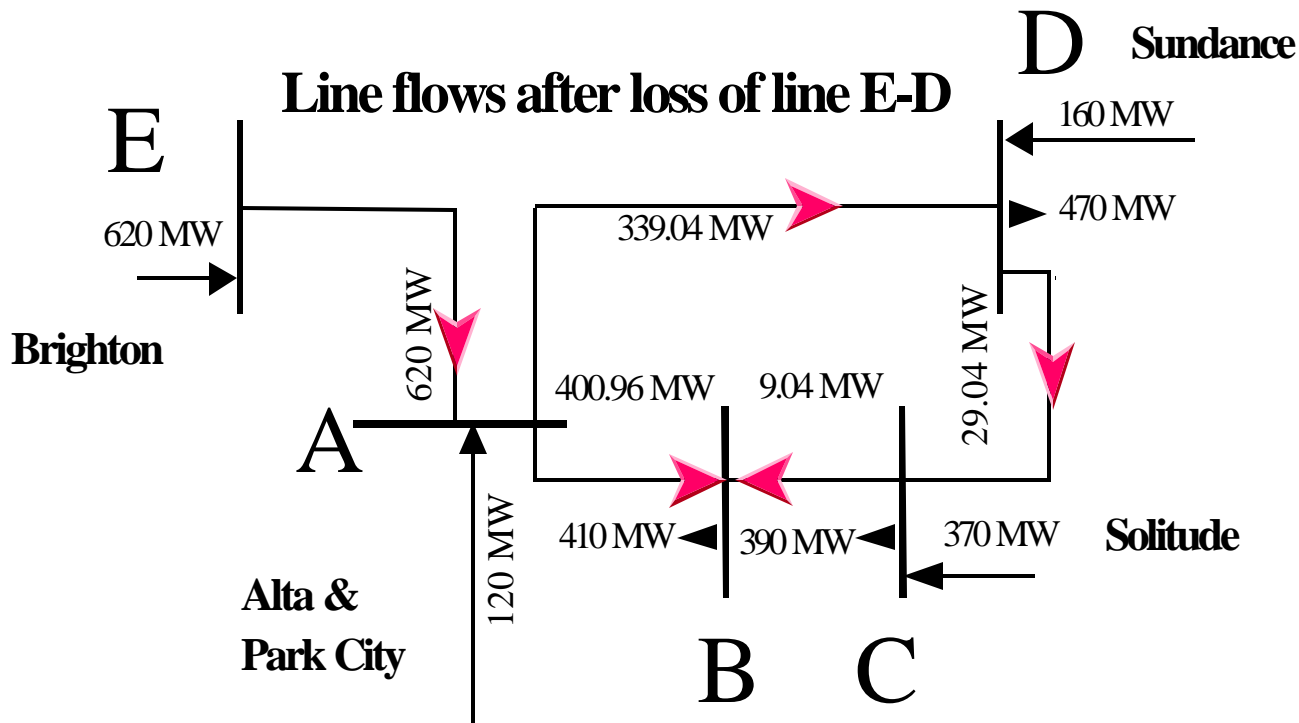

Transmission Line	Pre-Contingency Line Flows with All Lines In-Service	100% of Normal Limits	Post-Contingency Line Flows after Loss of Indicated Line						100% of Emergency Limits
			E-D	E-A	D-C	C-B	B-A	A-D	
E-D	249.71	240	0.00	620.00	201.38	210.53	397.95	358.48	440
E-A	370.29	400	620.00	0.00	418.62	409.47	222.05	261.52	600
D-C	105.72	240	29.04	219.42	0.00	20.00	430.00	48.48	440
C-B	85.72	350	9.04	199.42	-20.00	0.00	410.00	28.48	550
B-A	-324.28	250	-400.96	-210.58	-430.00	-410.00	0.00	-381.52	450
A-D	166.01	150	339.04	-90.58	108.62	119.47	342.05	0.00	350

Monthly FTR Auction Respecting Transmission Limits

10 of 180 MW E-B FTR Selected @\$20/MW
 200 of 200 MW E-C FTR Selected @\$30/MW
 10 of 10 MW E-B FTR Selected @\$25/MW
 0 of 10 MW E-C FTR Selected @\$10/MW

10 of 10 MW C-D FTR Returned @\$15/MW
 0 of 20 MW C-D FTR Returned @\$20/MW

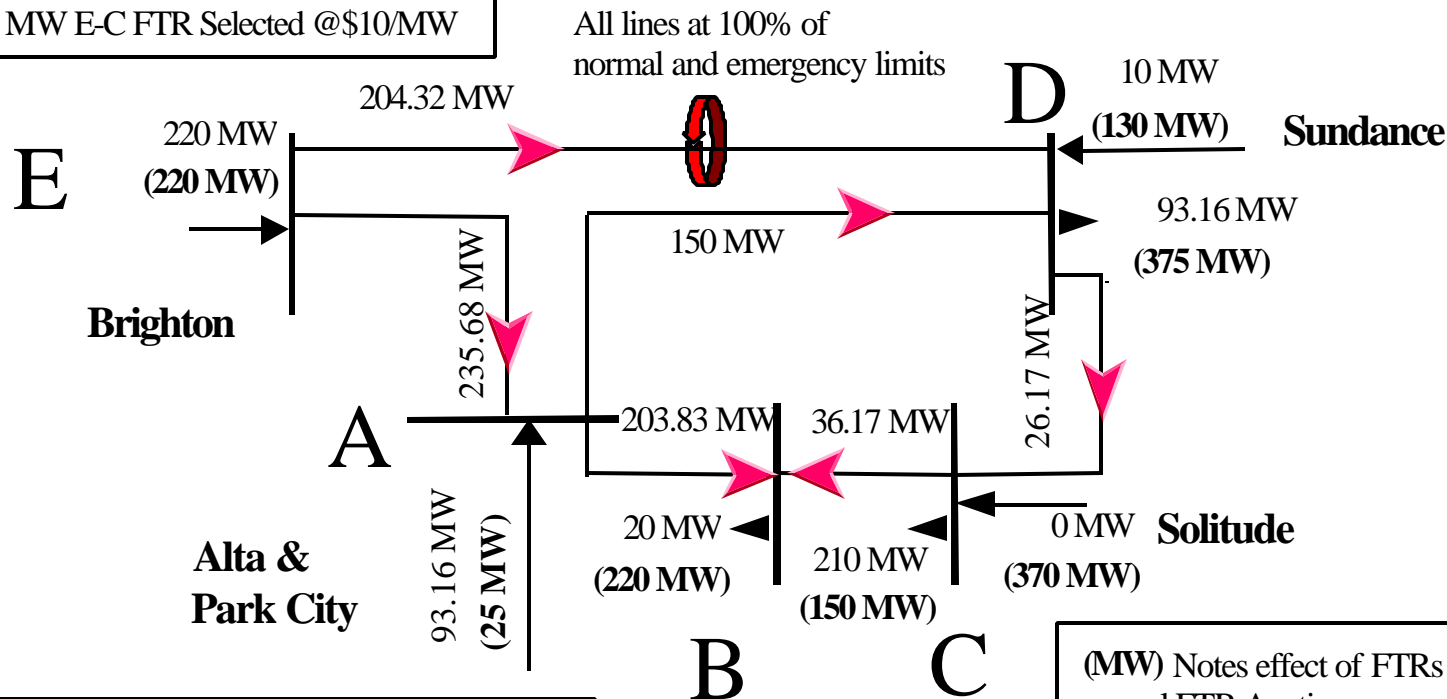

45.00 of 45 MW A-D FTR Selected @\$100/MW
 38.16 of 40 MW A-D FTR Selected @\$35/MW
 10.00 of 10 MW A-D FTR Selected @\$40/MW

(MW) Notes effect of FTRs awarded in annual FTR Auction

Total FTR Auction Value = \$12,535

Comparison of Line Flows with Limits - MW

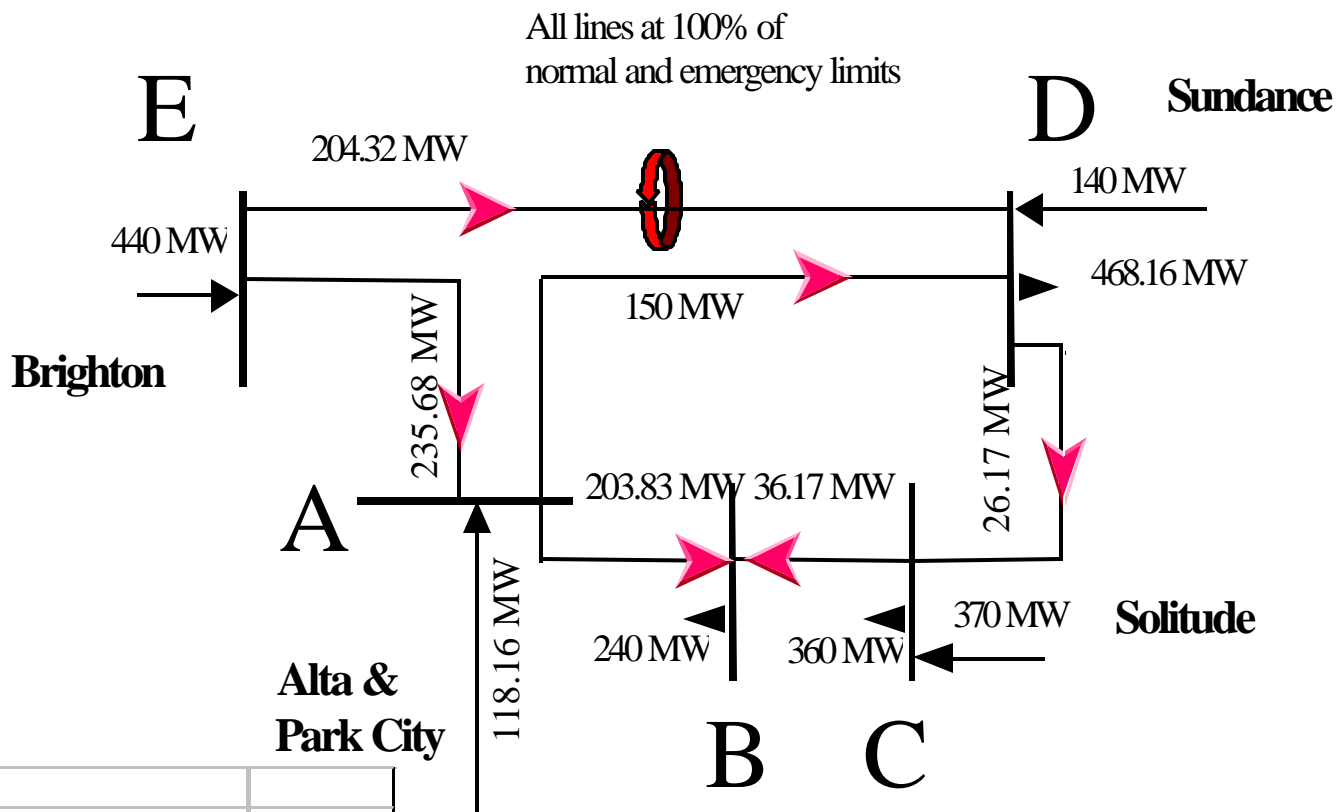

Transmission Line	Pre-Contingency Line Flows with All Lines In-Service	100% of Normal Limits
E-D	204.32	240
E-A	235.68	400
D-C	26.17	240
C-B	36.17	350
B-A	-203.83	250
A-D	150.00	150

Contingency Line Flows Compared with Limits - MW

Line flows after loss of line E-A

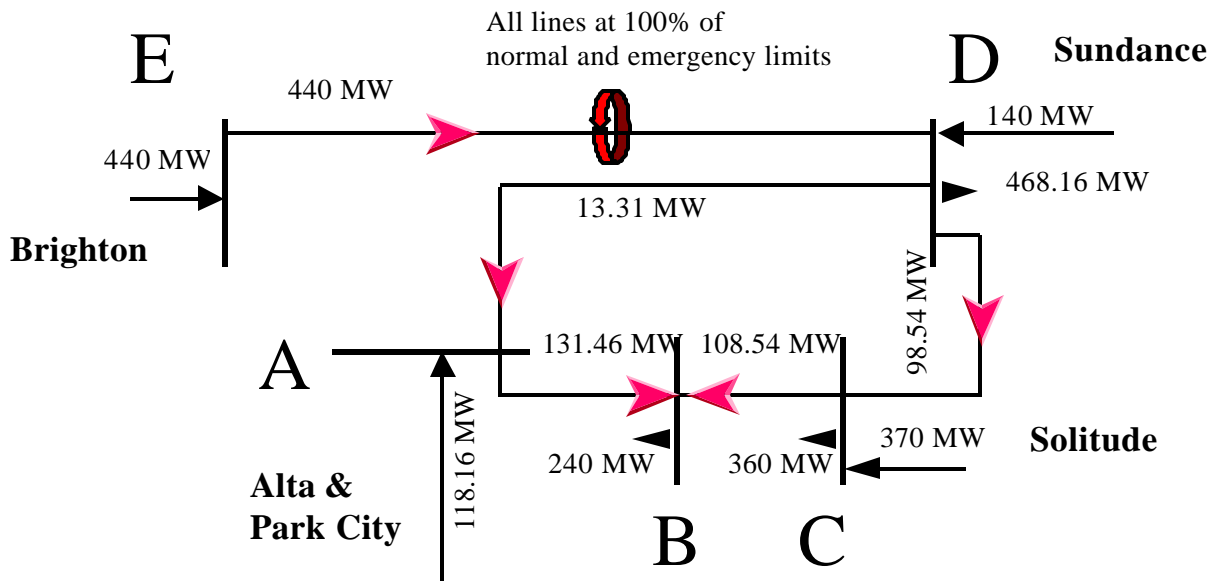

Transmission Line	Pre-Contingency Line Flows with All Lines In-Service	100% of Normal Limits	Post-Contingency Line Flows after Loss of Indicated Line						50% of Emergency Limits
			E-D	E-A	D-C	C-B	B-A	A-D	
E-D	204.32	240	0.00	440.00	192.36	187.79	297.50	302.60	440
E-A	235.68	400	440.00	0.00	247.64	252.21	142.50	137.40	600
D-C	26.17	240	-36.57	98.54	0.00	-10.00	230.00	-25.55	440
C-B	36.17	350	-26.57	108.54	10.00	0.00	240.00	-15.55	550
B-A	-203.83	250	-266.57	-131.46	-230.00	-240.00	0.00	-255.55	450
A-D	150.00	150	291.58	-13.31	135.80	130.37	260.65	0.00	350



Monthly FTR Auction Selection of Winning Bids & Offers

1	2	3	4		5 = 3 / 4		6	7 = 3 * 6	8 = 4 * 6	
Bid Path	Bid Quantity (MW)	Bid Price (\$/MW)	Sensitivity Factors ¹		Cost Effectiveness Ratio (\$/MW)		FTRs Selected (MW)	Auction Value \$	Flow on Constrained Lines (MW)	
			Line A-D	Line E-D	Line A-D	Line E-D			Line A-D	Line E-D
E-B	180	20	0.1017	1.0000	197	20	10	\$200	1.02	10.00
E-C	200	30	0.1706	1.0000	176	30	200	\$6,000	34.11	200.00
E-B	10	25	0.1017	1.0000	246	25	10	\$250	1.02	10.00
E-C	10	10	0.1706	1.0000	59	10	0	\$0	0.00	0.00
A-D	45	100	0.4376	0.0000	229	0	45	\$4,500	19.69	0.00
A-D	10	40	0.4376	0.0000	91	0	10	\$400	4.38	0.00
A-D	40	35	0.4376	0.0000	80	0	38.15515	\$1,335	16.70	0.00
Sell Offers	Sell Quantity	Sell Price								
C-D	10	15	-0.1895	0.0000	-79	0	10	-\$150	-1.89	0.00
C-D	20	20	-0.1895	0.0000	-106	0	0	\$0	0.00	0.00
Total Auction Value								\$12,535		
Line Flows Resulting from FTRs Awarded in the Annual FTR Auction									74.99	220.00
Total Flow on Constrained Transmission Lines									150.00	440.00

¹ Sensitivity factors change under contingencies. Sensitivity factors for line A-D are for all lines in-service. Sensitivity factors for line E-D result from the contingent loss of line E-A.



Monthly FTR Auction Clearing Prices

From Bus A	Calculation for Components of FTR Clearing Price		FTR Clearing Price = S Cost Components
	Binding Constraint A-D \$79.984	Binding Constraint E-D \$11.868	
A	Reference	Reference	\$0.00
B	$\$79.984 * 0.179245$	$\$11.868 * 0.0$	\$14.34
C	$\$79.984 * 0.248137$	$\$11.868 * 0.0$	\$19.85
D	$\$79.984 * 0.437588$	$\$11.868 * 0.0$	\$35.00
E	$\$79.984 * 0.077578$	$\$11.868 * -1.0$	-\$5.66

Lagrange Multiplier for Binding Constraint A-D

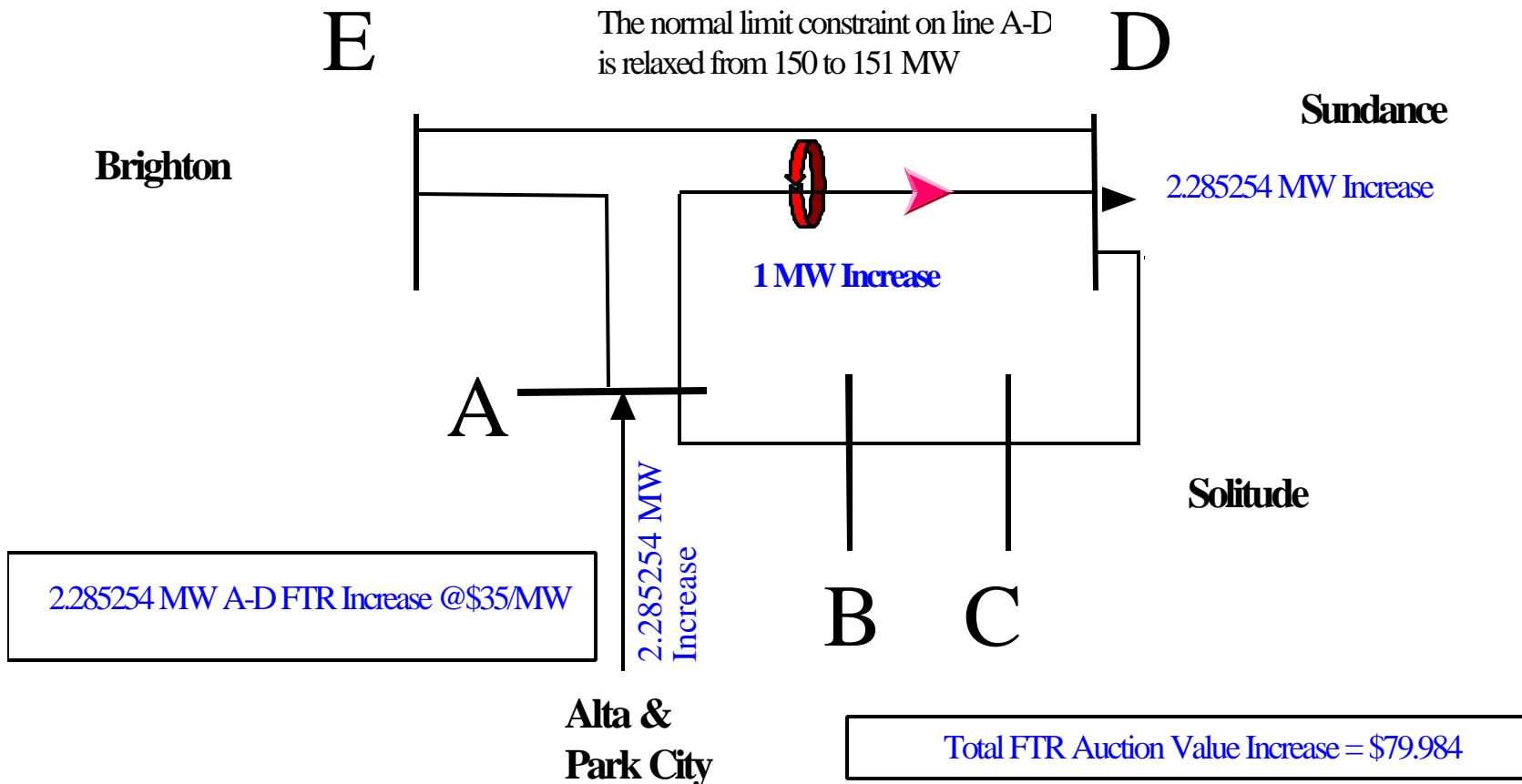

Bus D Sensitivity Factor for Constraint on A-D

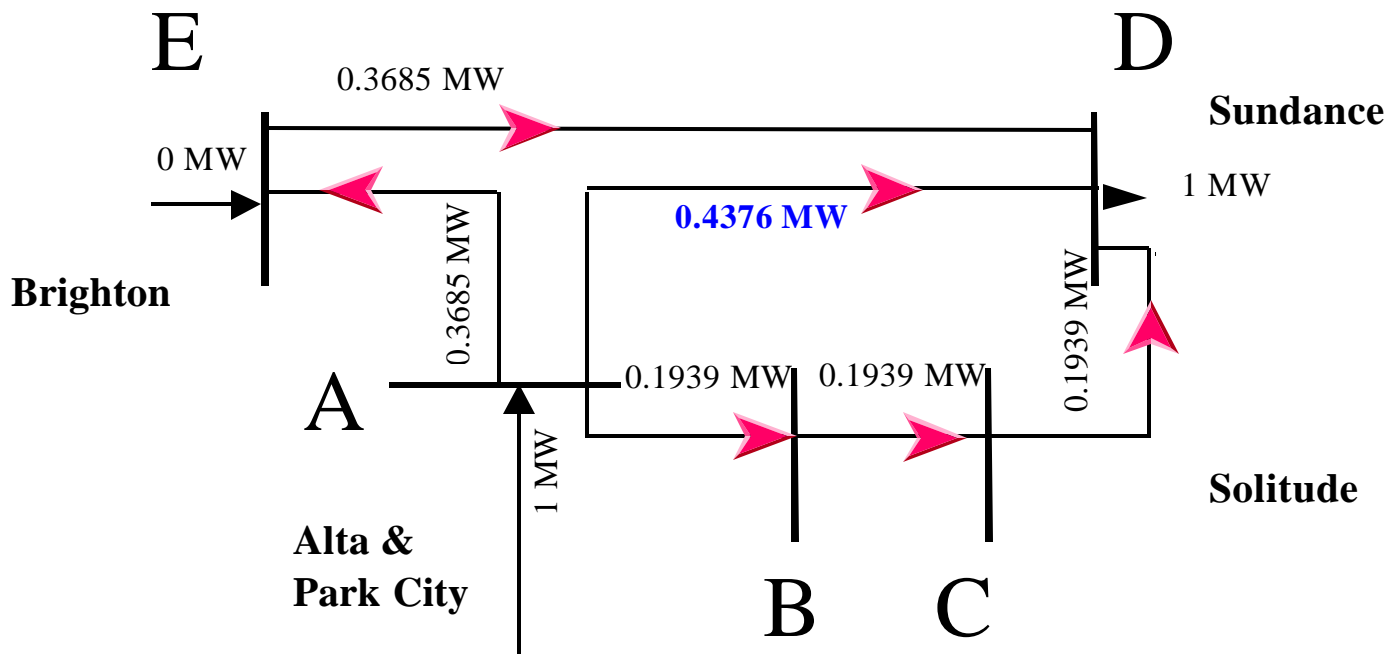

From Bus A	Calculation for Components of FTR Clearing Price	
	Binding Constraint A-D \$79.984	Binding Constraint E-D \$11.868
A	Reference	Reference
B	$\$79.984 * 0.179245$	$\$11.868 * 0.0$
C	$\$79.984 * 0.248137$	$\$11.868 * 0.0$
D	$\$79.984 * 0.437588$	$\$11.868 * 0.0$
E	$\$79.984 * 0.077578$	$\$11.868 * -1.0$

Lagrange Multiplier for Binding Constraint E-D

Line flows after loss of line E-A

The emergency limit constraint on line E-D is relaxed from 440 to 441 MW

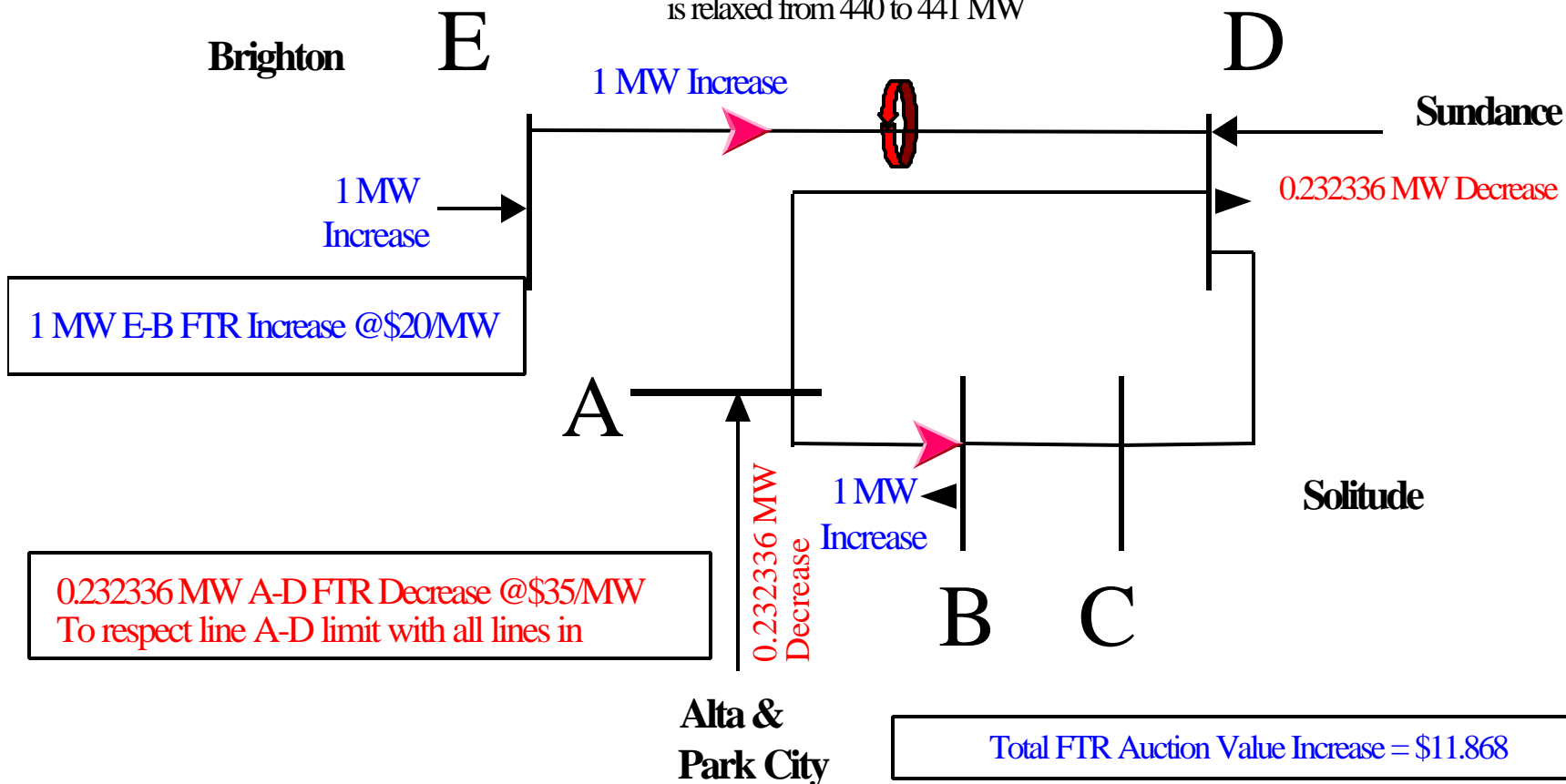

Bus E Sensitivity Factor for Constraint on E-D

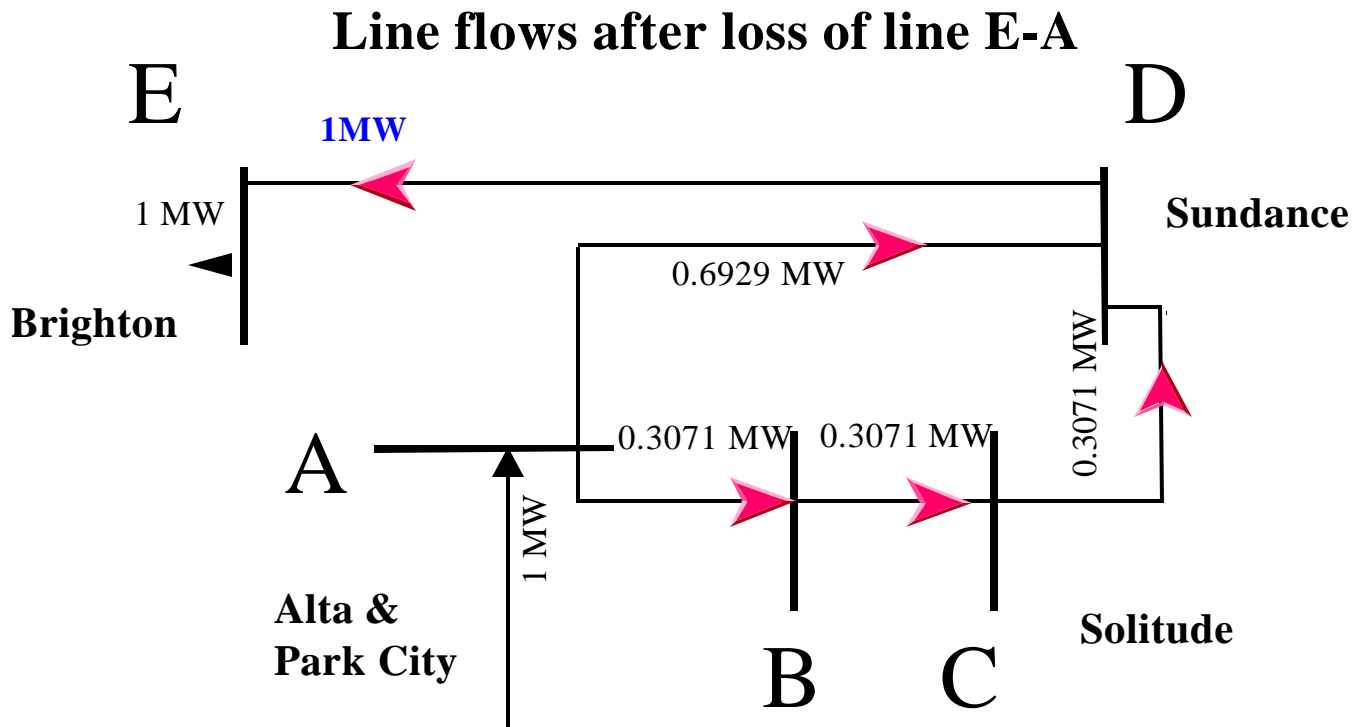

From Bus A	Calculation for Components of FTR Clearing Price	
	Binding Constraint A-D \$79.984	Binding Constraint E-D \$11.868
A	Reference	Reference
B	$\$79.984 * 0.179245$	$\$11.868 * 0.0$
C	$\$79.984 * 0.248137$	$\$11.868 * 0.0$
D	$\$79.984 * 0.437588$	$\$11.868 * 0.0$
E	$\$79.984 * 0.077578$	$\$11.868 * -1.0$

Monthly FTR Auction Respecting Transmission Limits

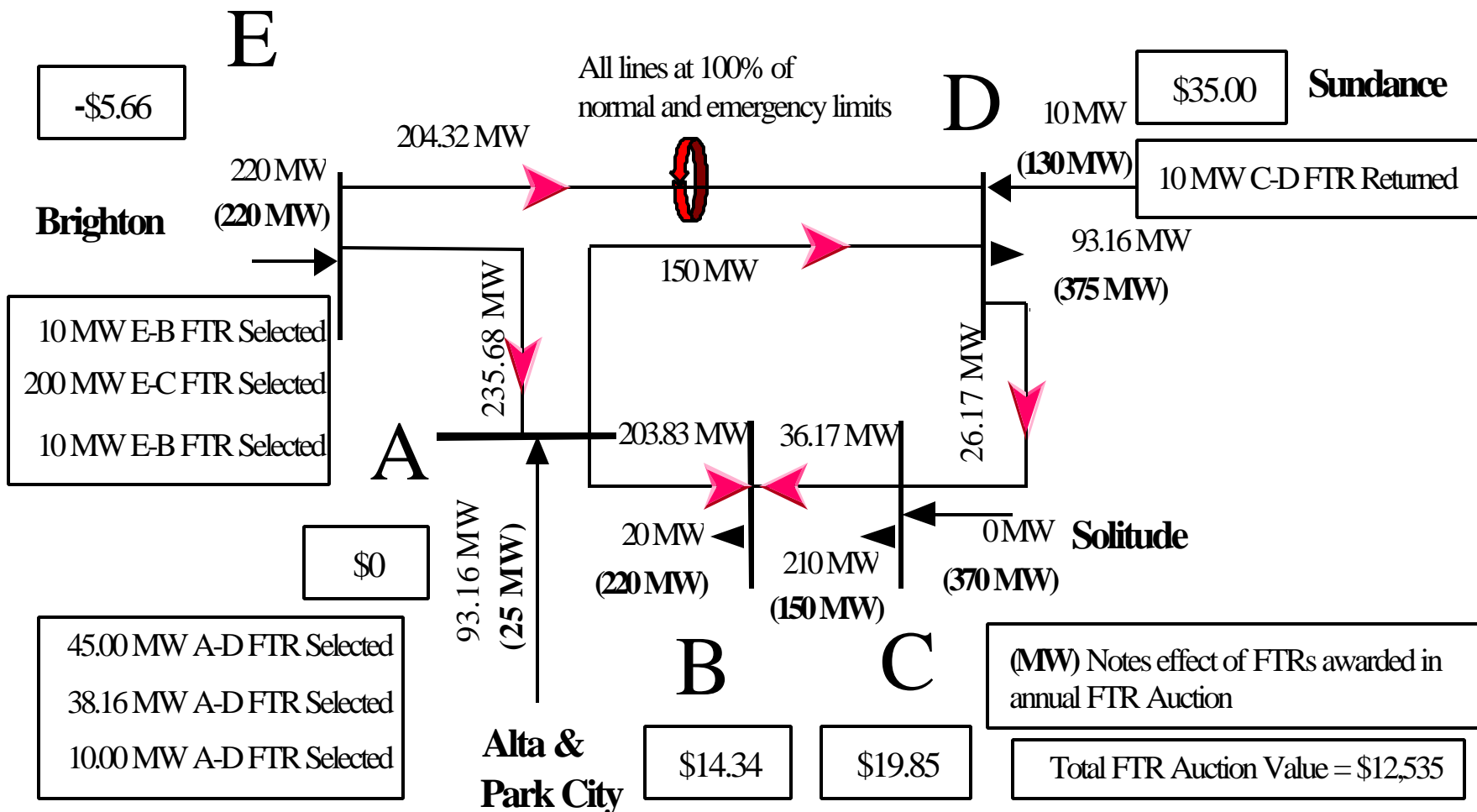



Monthly FTR Auction Clearing Prices

From Bus A	Calculation for Components of FTR Clearing Price		FTR Clearing Price = S Cost Components
	Binding Constraint A-D \$79.984	Binding Constraint E-D \$11.868	
A	Reference	Reference	\$0.00
B	$\$79.984 * 0.179245$	$\$11.868 * 0.0$	\$14.34
C	$\$79.984 * 0.248137$	$\$11.868 * 0.0$	\$19.85
D	$\$79.984 * 0.437588$	$\$11.868 * 0.0$	\$35.00
E	$\$79.984 * 0.077578$	$\$11.868 * -1.0$	-\$5.66

Monthly FTR Auction Clearing Prices by Path - \$/MW

Source \ Sink	A	B	C	D	E
A	0	14.34	19.85	35	-5.66
B	-14.34	0	5.51	20.66	-20
C	-19.85	-5.51	0	15.15	-25.51
D	-35	-20.66	-15.15	0	-40.66
E	5.66	20	25.51	40.66	0

Monthly FTR Auction Results

10 MW E-B FTR Awarded @\$20/MW
 200 MW E-C FTR Awarded @\$25.51/MW
 10 MW E-B FTR Awarded @\$20/MW

10 MW C-D FTR Sold @\$15.15/MW

E -\$5.66

Brighton

All lines at 100% of normal and emergency limits

D \$35.00 **Sundance**

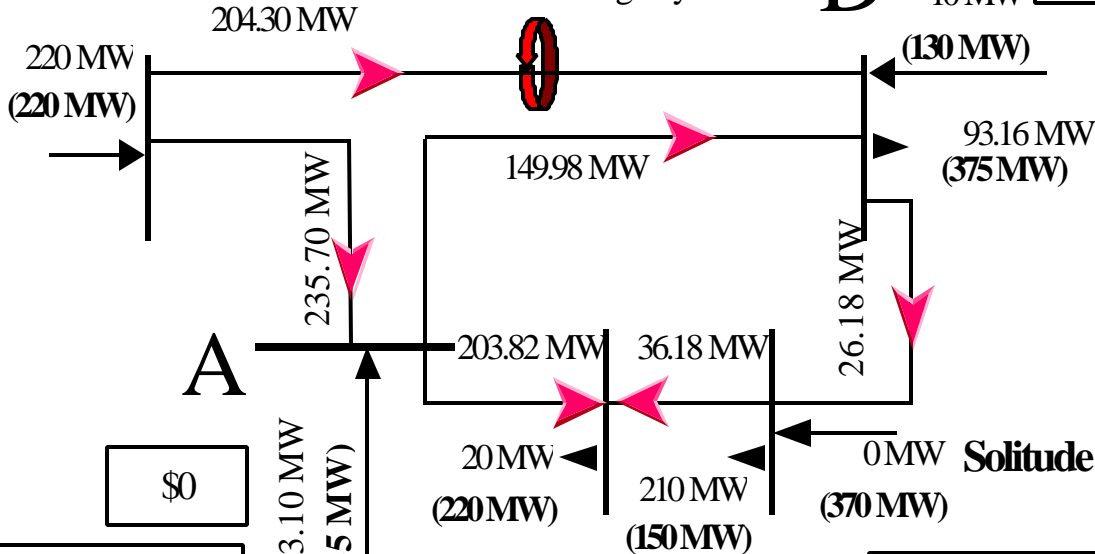

\$0

45.00 MW A-D FTR Awarded @\$35/MW
 38.10 MW A-D FTR Awarded @\$35/MW
 10.00 MW A-D FTR Awarded @\$35/MW

Alta & Park City

\$14.34

\$19.85

(MW) Notes effect of FTRs awarded in annual FTR Auction

Total FTR Auction Revenue = \$8,609



Constrained Day-Ahead Energy Market Dispatch Example

Day-Ahead Energy Market Supply Offers and Loads

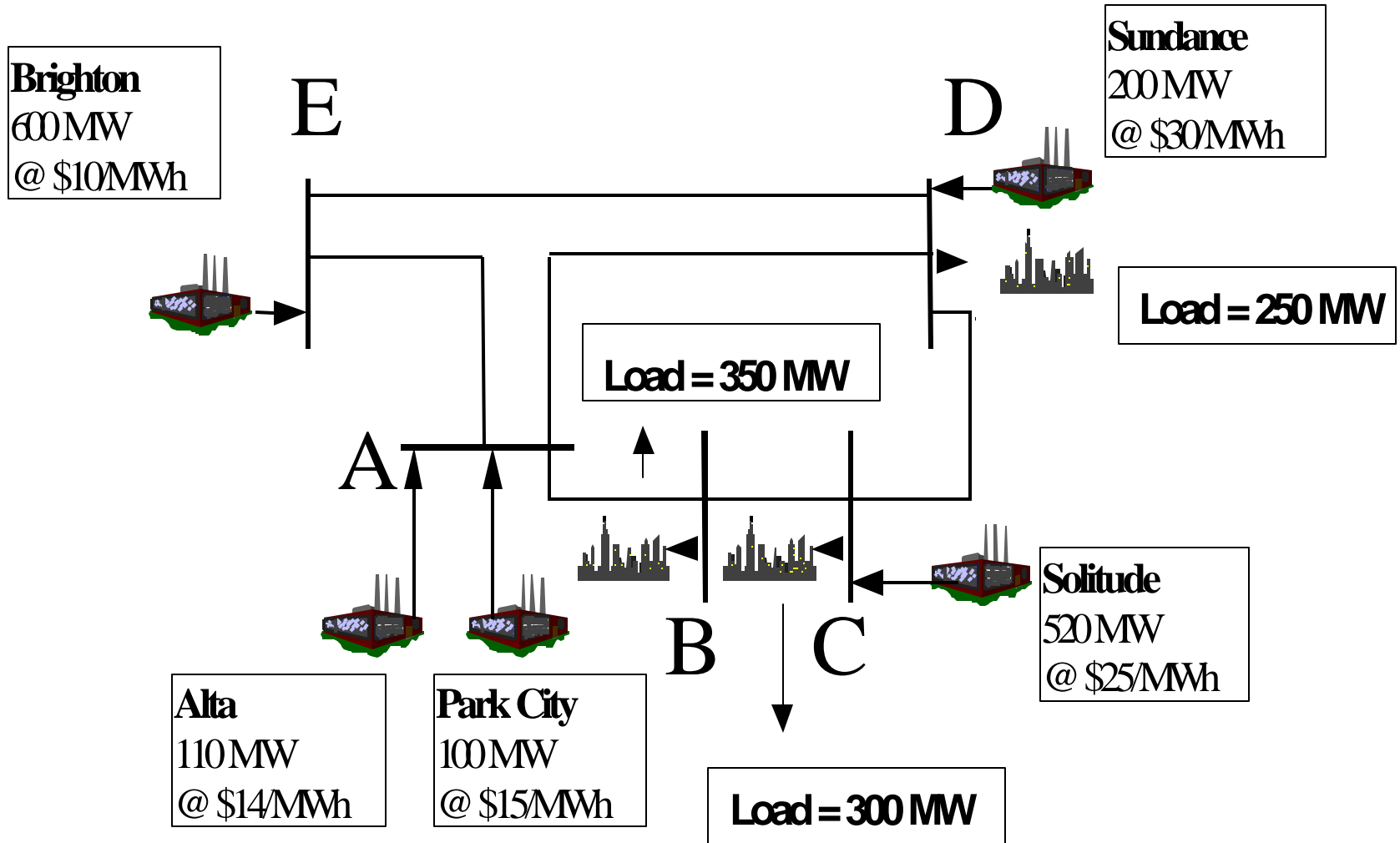

Dispatch Solution Ignoring Transmission Limitations

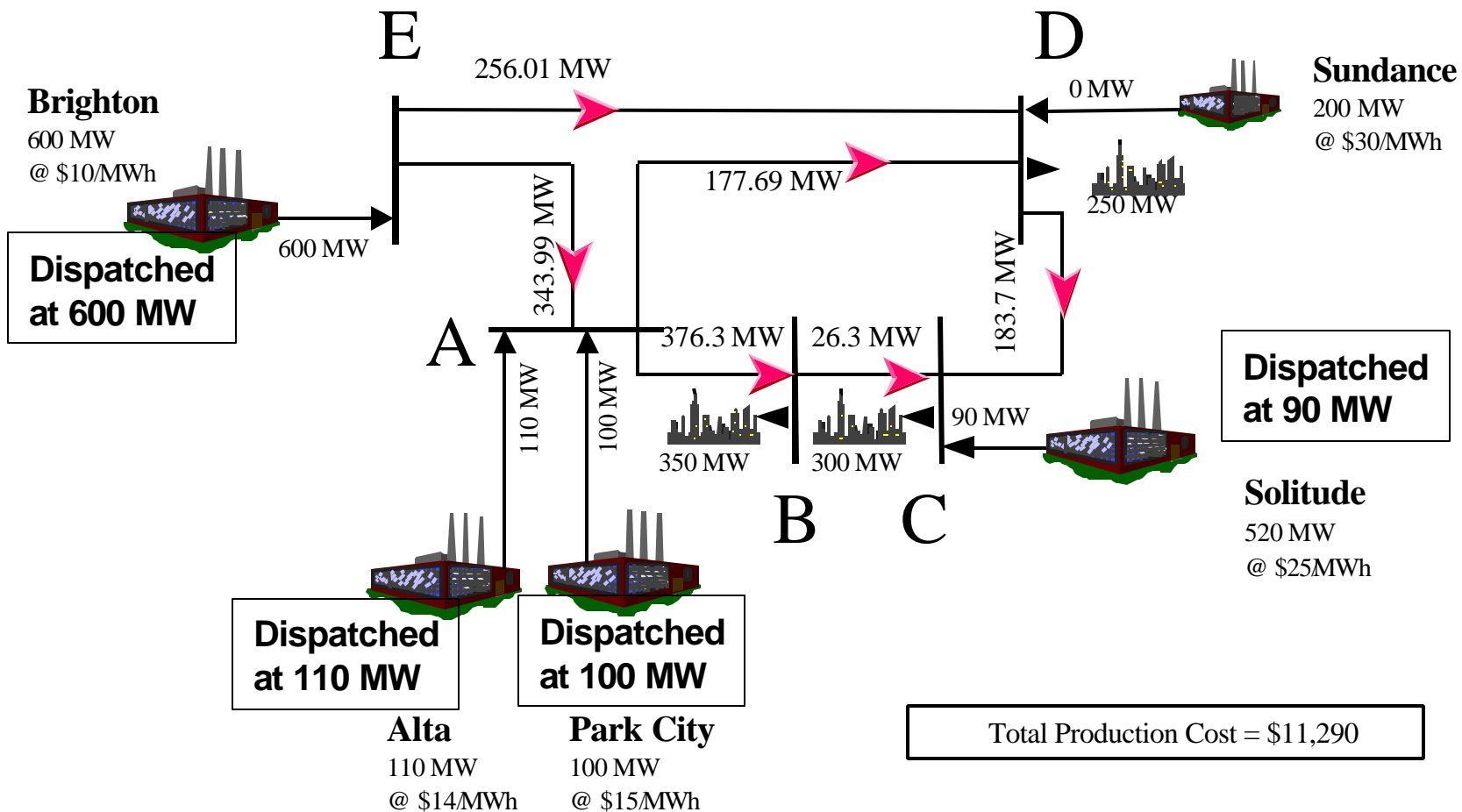

Dispatch Solution Ignoring Transmission Limitations

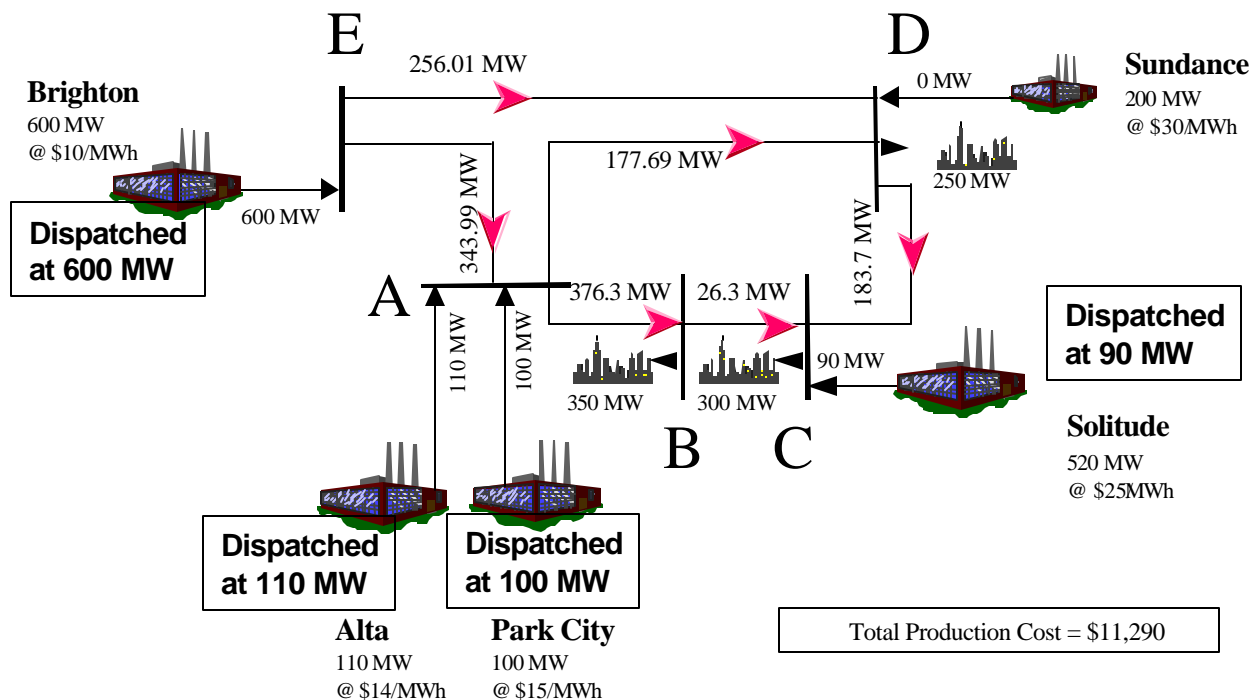

Transmission Line	Pre-Contingency Line Flows with All Lines In-Service	Normal Limits	Post-Contingency Line Flows after Loss of Indicated Line						Emergency Limits
			E-D	E-A	D-C	C-B	B-A	A-D	
E-D	256.01	240	0.00	600.00	172.03	268.03	428.03	372.44	440
E-A	343.99	400	600.00	0.00	427.97	331.97	171.97	227.56	600
D-C	183.70	240	105.09	289.33	0.00	210.00	560.00	122.44	440
C-B	-26.30	350	-104.91	79.33	-210.00	0.00	350.00	-87.56	550
B-A	-376.30	250	-454.91	-270.67	-560.00	-350.00	0.00	-437.56	450
A-D	177.69	150	355.09	-60.67	77.97	191.97	381.97	0.00	350

Dispatch Solution Respecting Transmission Limitations

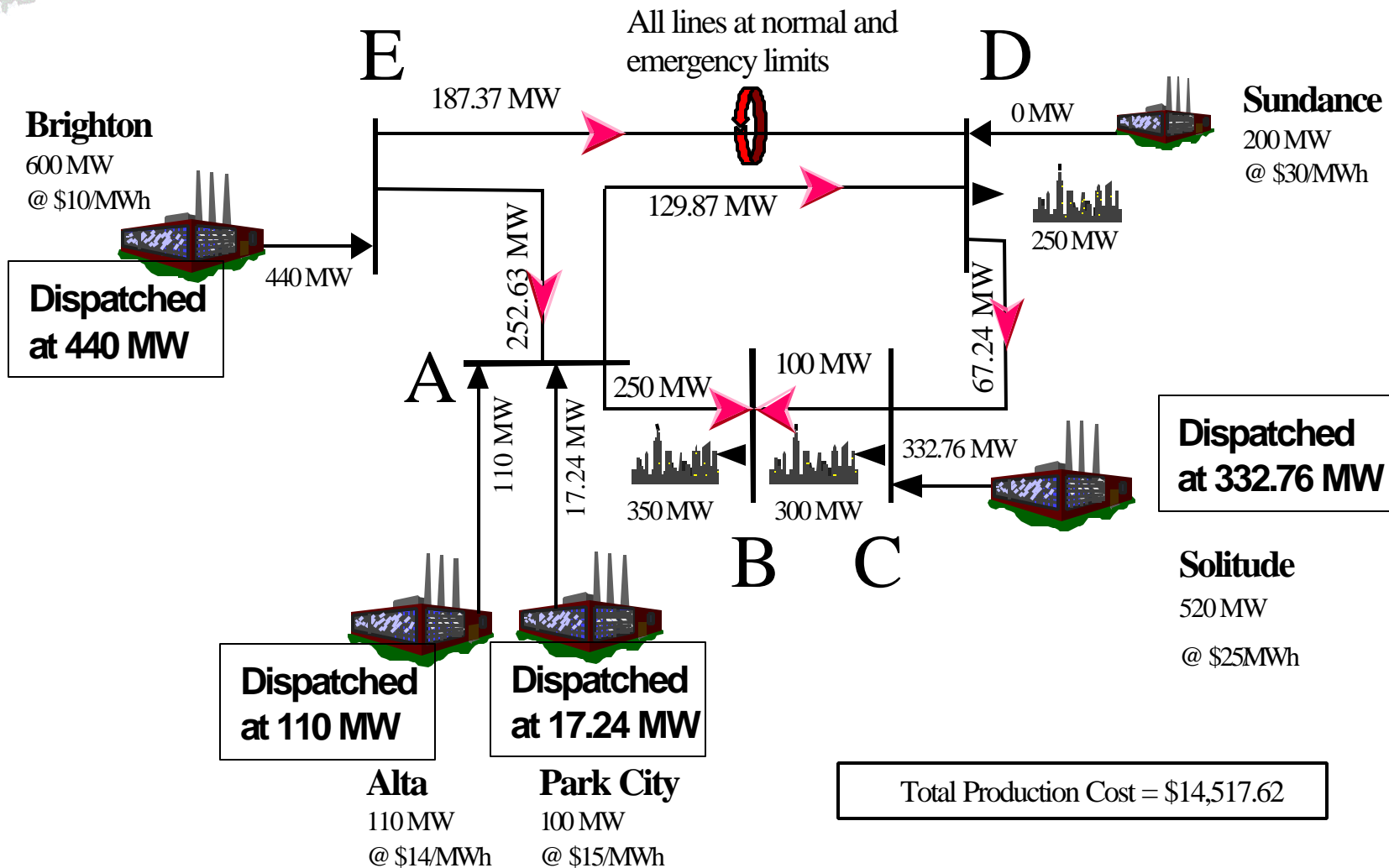

Dispatch Solution Respecting Transmission Limitations

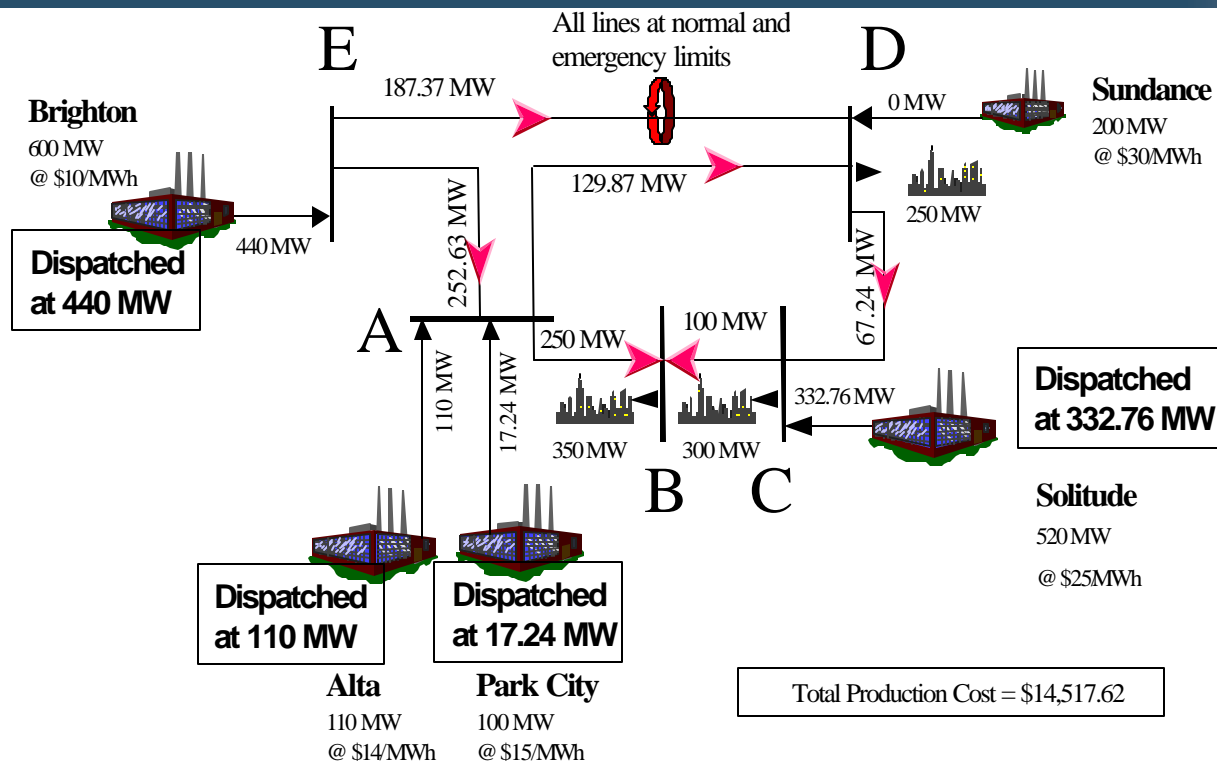

Transmission Line	Pre-Contingency Line Flows with All Lines In-Service	Normal Limits	Post-Contingency Line Flows after Loss of Indicated Line						Emergency Limits
			E-D	E-A	D-C	C-B	B-A	A-D	
E-D	187.37	240	0.00	440.00	156.63	141.65	301.65	272.46	440
E-A	252.63	400	440.00	0.00	283.37	298.35	138.35	167.54	600
D-C	67.24	240	9.70	144.81	0.00	-32.76	317.24	22.46	440
C-B	100.00	350	42.46	177.58	32.76	0.00	350.00	55.22	550
B-A	-250.00	250	-307.54	-172.42	-317.24	-350.00	0.00	-294.78	450
A-D	129.87	150	259.70	-45.19	93.37	75.58	265.58	0.00	350

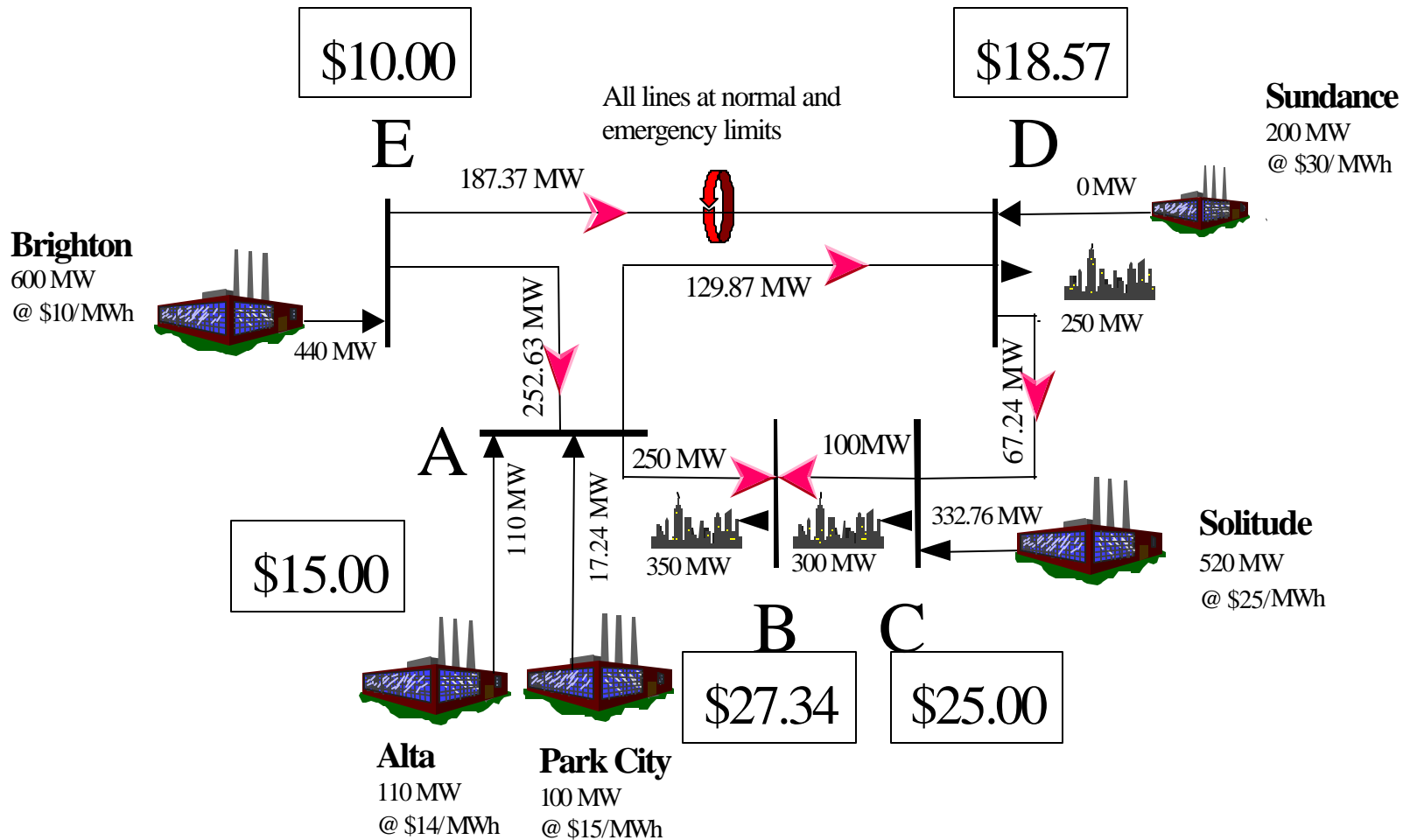

Marginal Generators

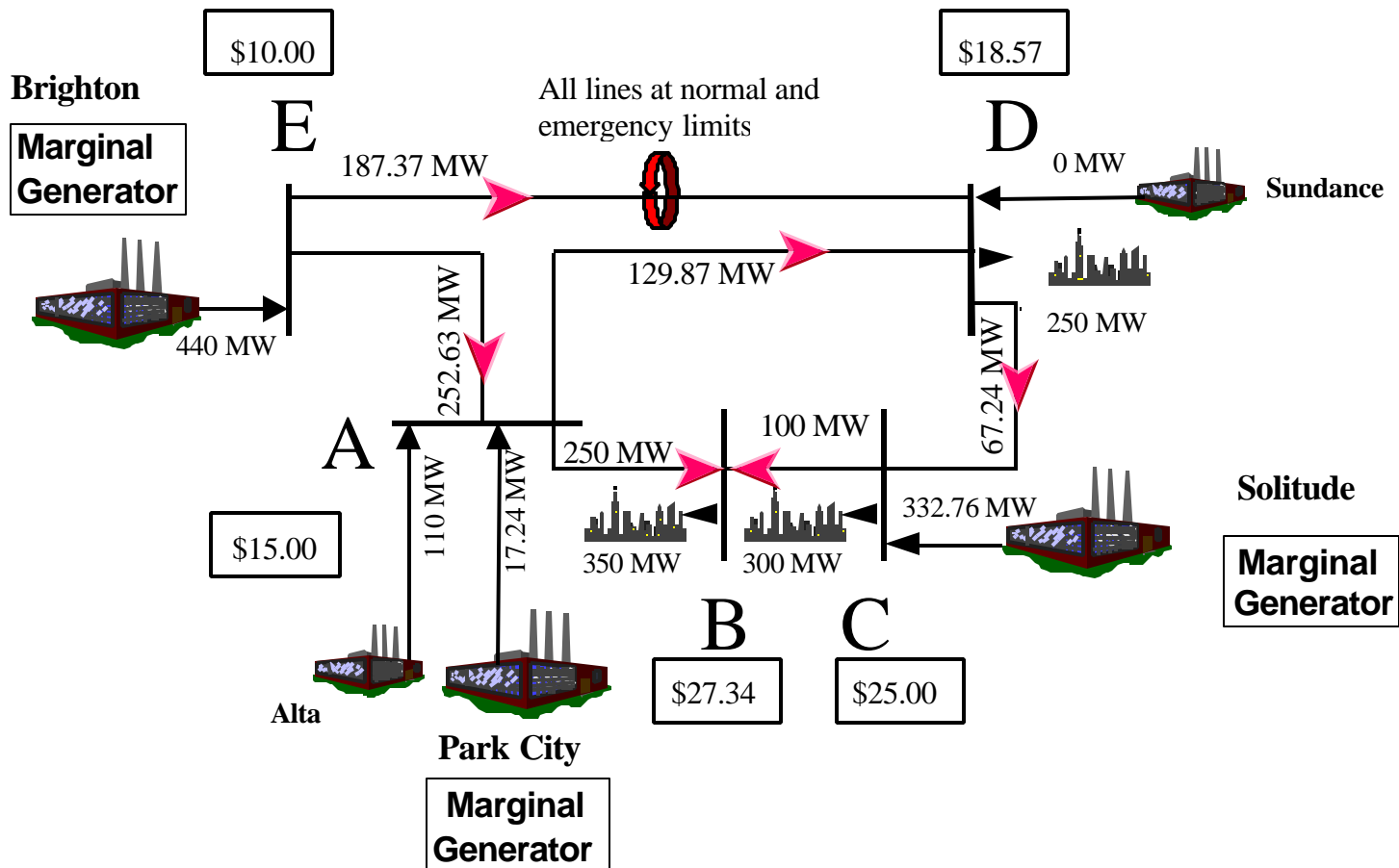

LMP Calculation

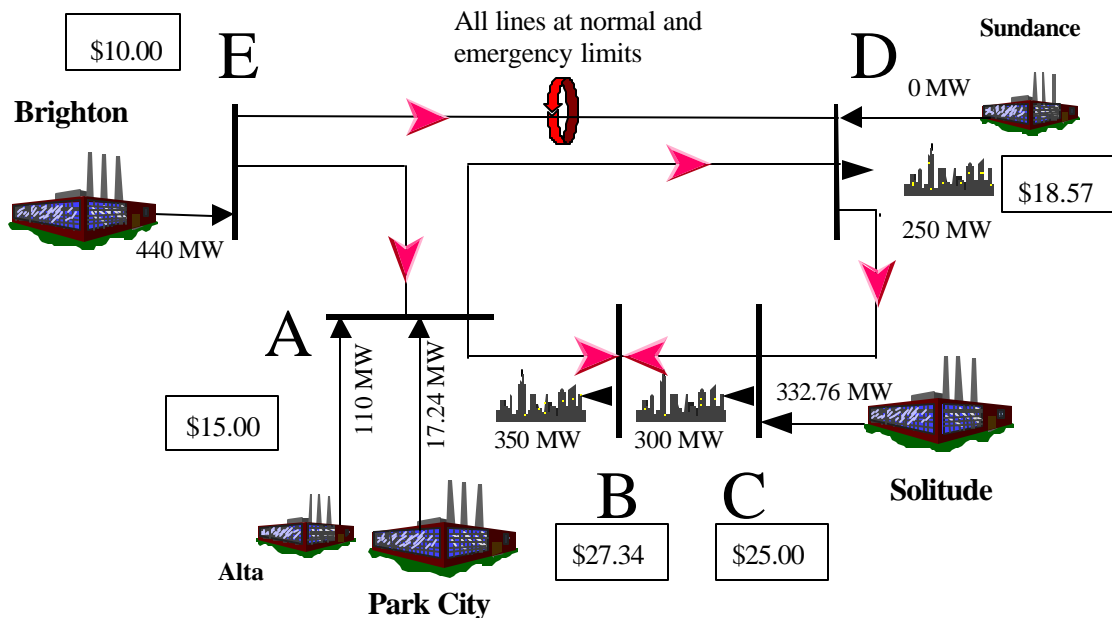

Bus Location	Marginal Generator Contribution to LMP			LMP = S Marginal Generator Contributions
	Park City @ \$15.00	Solitude @ \$25.00	Brighton @ \$10.00	
A	$\$15 * 1.0000$	$\$25 * 0.0000$	$\$10 * 0.0000$	\$15.00
B	$\$15 * -0.2338$	$\$25 * 1.2338$	$\$10 * 0.0000$	\$27.34
C	$\$15 * 0.0000$	$\$25 * 1.0000$	$\$10 * 0.0000$	\$25.00
D	$\$15 * 0.6428$	$\$25 * 0.3572$	$\$10 * 0.0000$	\$18.57
E	$\$15 * 0.0000$	$\$25 * 0.0000$	$\$10 * 1.0000$	\$10.00

Congestion Charge Calculation

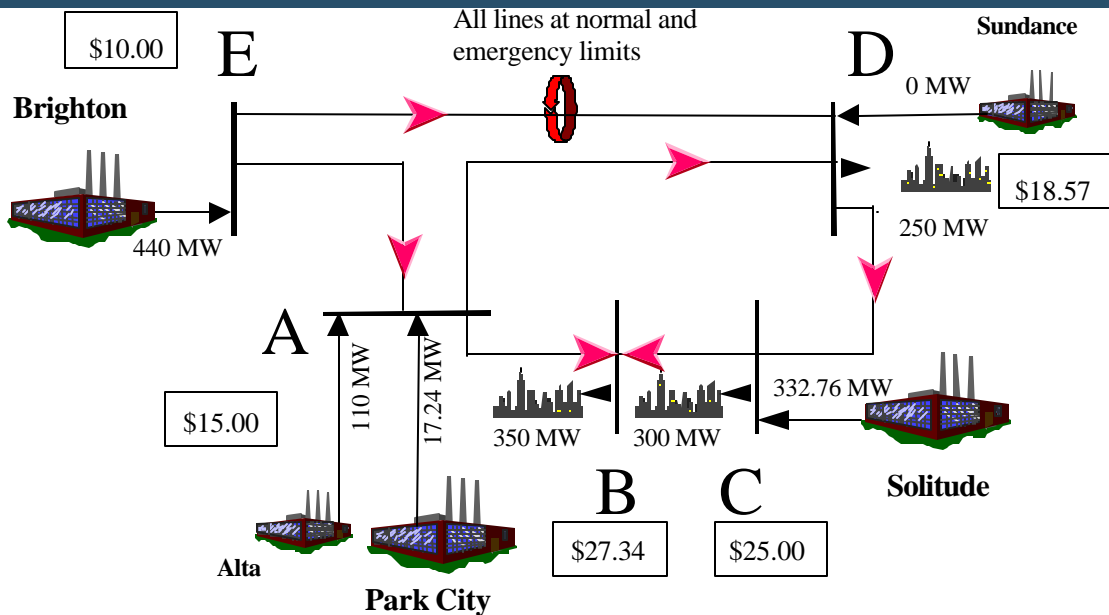

Bus Location	LMP Cost Components			LMP = S Cost Components
	Energy Component	Congestion Component	Marginal Loss Component	
A	\$15	\$0	\$0	\$15.00
B	\$15	\$12.34	\$0	\$27.34
C	\$15	\$10.00	\$0	\$25.00
D	\$15	\$3.57	\$0	\$18.57
E	\$15	-\$5.00	\$0	\$10.00



Congestion Charge Calculation

$$\begin{aligned} \text{Total load charges} = & (350 \text{ MW at Bus B} * \$12.34/\text{MW}) + \\ & (300 \text{ MW at Bus C} * \$10.00/\text{MW}) + \\ & (250 \text{ MW at Bus D} * \$3.57/\text{MW}) \end{aligned}$$

$$\text{Total load charges} = \$8,211.50$$

The congestion cost as each generator (injection Node) is equal to the MW output of the generator times the Congestion Component of the LMP at that bus. Total generation credits are the sum of all of the generator credits.

$$\begin{aligned} \text{Total generation credits} = & (440 \text{ MW at Bus E} * \$-5.00/\text{MW}) + \\ & ((110 \text{ MW} + 17.24 \text{ MW at Bus A}) * \$0.00/\text{MW}) + \\ & (332.76 \text{ MW at Bus C} * \$10.00) \end{aligned}$$

$$\text{Total generation credits} = \$1,127.60$$

$$\begin{aligned} \text{Congestion Charge} = & \text{total load charges (over all withdrawal Locations)} \\ & - \text{total generation credits (over all injection Node)} \end{aligned}$$

$$\text{Congestion Charge} = \$8,211.50 - \$1,127.60 = \mathbf{\$7,083.90}$$

This \$7,083.90 Congestion Charge is distributed to FTR Holders.



Settlement of FTRs in the Day-Ahead Energy Market



Settlement

Distribution of Day-Ahead Market FTR Target Allocation

<u>FTR</u>	<u>Congestion Component</u>		<u>Positive Target</u>
	<u>Source</u>	<u>Sink</u>	<u>Allocation</u>
220 MW from E to B	-\$5.00	\$12.34	\$3,814.80
200 MW from E to C	-\$5.00	\$15.00	\$3,000.00
25 MW from A to D	\$0.00	\$3.57	\$ 89.25
150 MW from C to C	\$10.00	\$10.00	\$ 0.00
130 MW from D to D	\$3.57	\$3.57	\$ 0.00
93.1 MW from A to D	\$0.00	\$3.57	\$ 332.37
20 MW from E to B	-\$5.00	\$12.34	\$ 346.80
			<u>\$7,583.22</u>

<u>FTR</u>	<u>Congestion Component</u>		<u>Negative Target</u>
	<u>Source</u>	<u>Sink</u>	<u>Allocation</u>
210 MW from C to D	\$10.00	\$3.57	\$1,350.30



Settlement

Settlement of FTRs in the Day-Ahead Market

Day-Ahead Market Congestion Charges	\$7,083.90
Negative FTR Target Allocation	<u>\$1,350.30</u>
	\$8,434.20
Positive FTR Target Allocation	\$7,583.22
ISO Managed Cash Fund	\$850.98

Note that FTRs do not hedge against losses.

To the PJM Interconnection for providing their FTR example upon which this example is based

To Dr. N. S. Rau for his tutelage in optimization theory



?

Questions?